

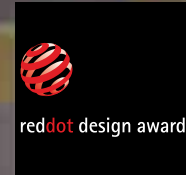

**Bauknecht**  
GERMANY SINCE 1919

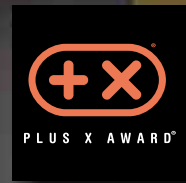







# THE AWARD-WINNING FORMULA

**Bauknecht epitomises true german heritage by adopting the famed bauhaus philosophy of “less is more”.**

For over 90 years, this belief has formed the blueprint of all Bauknecht's designs in crafting every piece of innovation, through meticulous attention to detail and a passion for perfection. It is no wonder that Bauknecht has garnered over 130 international awards in the last 8 years, including:

- Best of the best, kitchen innovation award 2012-2015
- Consumer's favourite brand, platinum, kitchen innovation award 2014
- Most innovative brand, plus x award 2009-2011, 2013
- Best designed brand, plus x award 2013
- Best product of the year - kosmos collection, plus x award 2010-2012



# BREATHTAKING DESIGN

**Germany is renowned for products of quality, but at Bauknecht, what makes our latest appliances special is the fact that they are inspired by the essential. Bauknecht represents a new generation in product design allowing all kitchen and interior design styles to be combined.**

## KOSMOS COLLECTION

A graceful fusion of modern elegance and practical function, is equipped with a distinctive mirrored surface and integrated handles that complement the contemporary streamlined, handle-free kitchen cabinets. The touch-sensitive ProCook LCD display of KOSMOS appliances, combined with top notch innovations, facilitate intuitive controls to give users an enjoyable kitchen experience of the 21st century. It's no wonder that the KOSMOS oven was also awarded the seal of quality when it won the Kitchen Innovation of the year, gold award 'Best of the Best', and the iF product design award.

## KOMFORT COLLECTION

The award-winning collection features elegant lines and streamlined handles that will remain attractive for many years to come. After all, durability, in terms of both function and design, is an important element for product design at Bauknecht. It is therefore not surprising that the oven, microwave and steamer in the KOMFORT collection have been recognised for their outstanding, timeless design with the iF Product Design Award.





# CUTTING EDGE TECHNOLOGY

**At Bauknecht, quality is shaped by innovation that sets out to find solutions for everyday life. Technology driven performance completes Bauknecht's story of excellence, a story rightfully honoured by prestigious industry recognition.**

## POWERDRY TECHNOLOGY

The innovative PowerClean+ high-pressure water jet system powerfully removes even the most stubborn of soiling from dishes – making pre-rinsing unnecessary. Thanks to Bauknecht's PowerDry technology. The unique ventilation system draws humidity from the interior of the appliance using dual air circulation and condenses it. This allows all dishes to be cleaned and extraordinarily well dried in just one hour – making Bauknecht PowerDry dishwashers faster than all the others on the market. This was reason enough for the jury of the Kitchen Innovation of the Year 2014 Award to confer the "Consumer's Favourite Brand - Platinum" prize.







# ECO-INNOVATIONS

**Sustainability is an integral part of our product development process – our innovative kitchen solutions focus on high performance and minimising the use of resources. Energy consumption, energy management and consumer education are important agendas at our design powerhouse: through incorporating appliance integration and the reuse of resources into future product designs, we help our customers achieve their sustainable living goals.**

## PURE CLEAN

Bauknecht's patented PureClean Technology utilises a sustainable enamel coating with dirt repellent properties and unique Nano Technology applied to the oven door. With an innovative cleaning cycle lasting 35 minutes that heat up to 90°C, the oven can be wiped clean effortlessly without the use of chemicals.

## PROFRESH TECHNOLOGY

The patented Profresh Technology, together with Green Intelligence™ Technology, precisely monitors humidity and temperature. Food items stay fresh up to 4 times longer in your Bauknecht refrigerator than under conventional storage conditions, with valuable nutrients freshly preserved for your daily enjoyment.







# TABLE OF CONTENTS

## **BAUKNECHT'S KITCHEN SERIES**

2 - 3 The Award-Winning Formula

4 - 5 Breathtaking Design

6 - 7 Cutting Edge Technology

8 - 9 Eco-Innovations

## **PRODUCT INFORMATION**

### **FOOD PREPARATION**

12 - 29 Oven

30 - 39 Steamer

40 - 55 Microwave Oven

56 - 65 Coffee Maker & Warmer Drawer

66 - 77 Cookerhood

78 - 91 Hob

### **FOOD PRESERVATION**

92 - 117 Refrigerator & Wine Cellar

### **WASHING & CLEANING**

118 - 125 Dishwasher

126 - 135 Washer

“Love begins by  
taking care of  
the closest ones.”



# OVENS

WE CARE ABOUT YOUR OVEN AND ALSO THE ENVIRONMENT

Bauknecht's continual technological innovations are not to make things complicated, but to streamline processes. Its first-in-market "no preheating technology" enables flawless cooking on three layers, without the mix of tastes and aromas, saving your time.

Furthermore, the patented PureClean technology makes cleaning so easy and environmentally-friendly, it's no wonder the KOSMOS oven with PureClean won the 2012 iF product design award.



# Unrivalled performance for improved time and energy efficiency



NO NEED TO  
**PRE-HEAT**

## PREHEAT-FREE TECHNOLOGY: TIME AND ENERGY SAVING

Thanks to the Intelligent Heating concept featuring optimised air circulation, the patented heat algorithm gives the perfect heat distribution in each point of the oven cavity, even during multi-level cooking. At the same time, Bauknecht's powerful convection system heats up food evenly and quickly, saving you the trouble of preheating your oven. This way, food preparation time is reduced by up to 26% and energy consumption by as much as 20%.

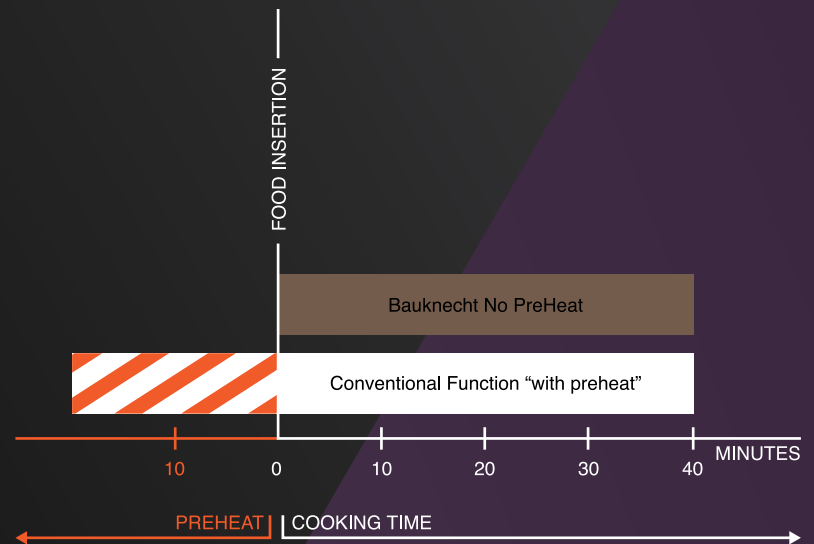

- The food is placed into a cold cavity and the temperature gradually increases so that the food doesn't brown too quickly, and prevents the food burning by the end of the cooking cycle.
- The 30 Sensor recipes are by default set with no preheating function.



## multi level COOKING

### PERFECT MULTI-LEVEL COOKING WITH NO MIXING OF ODOURS

With up to 30% more cooking space, you can prepare a complete meal simultaneously, and not worry about odours, tastes and aromas mixing. Pamper your palates with sumptuously delicious foods as you indulge in green and sustainable cookery.

# Functions to enhance your cooking experience



## SOFT CLOSING DOOR

Soft closing of the door allows for a more ergonomic feel and an enhanced quality perception. The new dumper device and hinges create a “cushion” effect at just a slight push. This is not only quieter, but also protects the furniture and lengthens the lifespan of the oven.



## MEAT PROBE SENSOR FOR PERFECT ROASTING

The meat probe of your Bauknecht oven can be programmed to detect temperatures between 30°C and 100°C. Simply insert the sensor into the thickest part of the meat, select the target core temperature and relax. You will be notified with an audio signal when perfect roasting has been achieved, and your oven will switch off automatically.



## 30 AUTOMATIC RECIPES FOR BEST COOKING RESULTS

30 automatic recipes gathered from ideal cooking parameters let you cook like a Master Chef. While cooking with one of the 30 automatic recipes available, an energy sensor measures different energy parameters, and adapts the cooking time accordingly to provide the best results.

## SLOW COOK



### TENDERNESS AND SUCCULENCE GUARANTEED

With slow cooking, meat and fish are cooked at the lowest temperatures: 90°C for 4-7 hours for meat and 85°C for 2-5 hours for fish, depending on the size of the joint or cut. This not only ensures that food remains tender and succulent, but also preserves nutrients and flavours.

## **73** CAVITY



### EXTRA LARGE CAVITY FOR BETTER RESULTS

The new ovens retain the sleek, technological and beautiful appearance characteristic of Bauknecht appliances, but have a cavity that is expanded to 73L – compared to the conventional 52-55L. Multi-level cooking is even better supported to deliver exceptional cooking results.

## SLIDING RUNNERS



### COOKING MADE EFFORTLESS AND SAFE

A sliding runner design makes the insertion and removal of accessories a smooth and effortless process. This way, cooking with the oven becomes easier and safer than ever before.



We not only care about your oven,  
but also of you



pure  
clean™

## THE WORLD'S ONLY EFFECTIVE OVEN CLEANING METHOD THAT DOES NOT HARM THE WORLD

Bauknecht's patented PureClean Technology utilises a sustainable, enamel-coating with dirt repellent properties, with unique Nano technology applied to the oven door. Even the baking trays feature a special coating for easier cleaning. With an innovative cleaning cycle lasting 35 minutes that heats up to 90°C, as well as a special absorbent cloth dampened with water, the oven can be wiped clean effortlessly without the use of chemicals. It also guarantees cleaning results that are 10 times better than when using detergents, even with tough soils like tomato and grease. What's more, PureClean achieves considerable energy savings of 97%\*, whereas the scratch resistance coating has a life span of 10 years.



Scan to understand more about  
PureClean Technology.

\* Compared with pyrolytic cleaning





Inner door glass with special Nano-treatment and dirt-repellent properties.

Special low silica enamelled cavity with easy to clean properties  
Water-activated enamel, no need to use aggressive and polluting detergents.

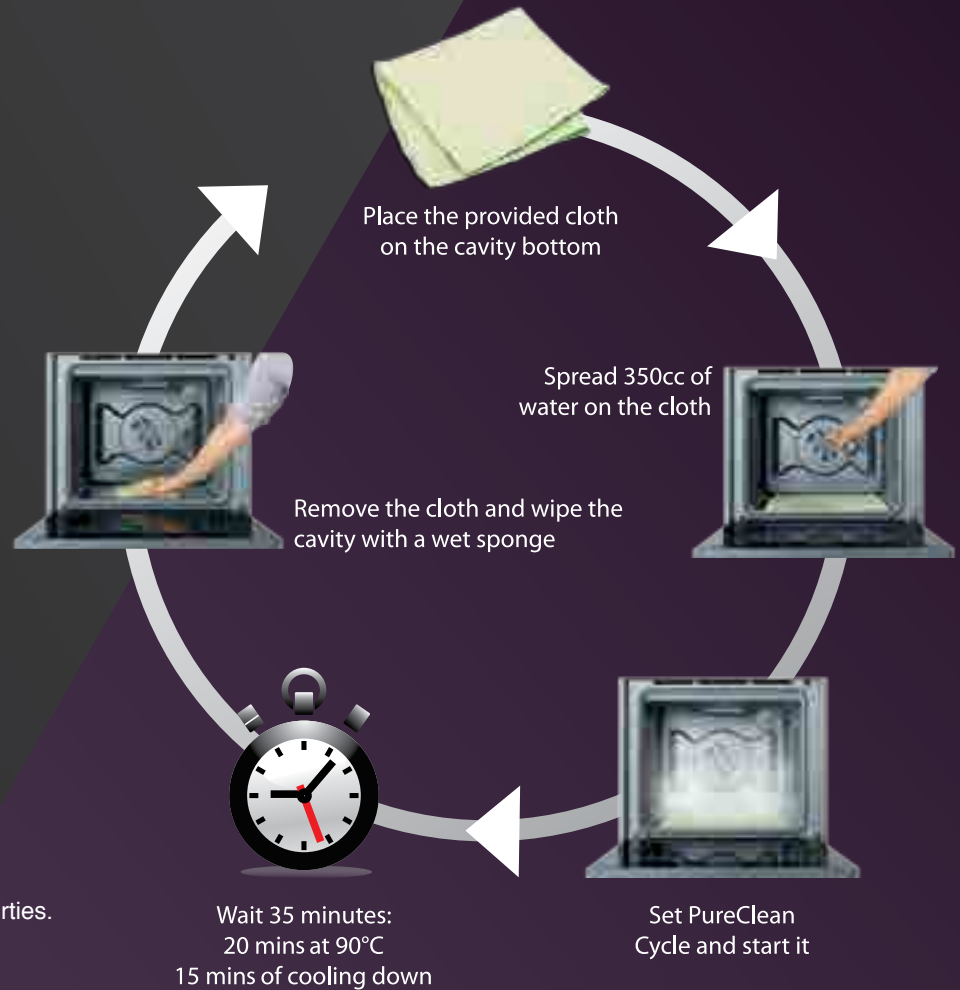

# Ovens that care



## PYROLYTIC



### BURN ALL GREASE AT 500°C FOR IMMEDIATE REMOVAL

Pyrolytic function heats up the cavity to over 500°C, burning grease and dirt. All you have to do is wipe out the ashes after the cavity cools down.

Pyrolytic Self-Clean, which can run straight after baking, offers two settings for different degrees of dirtiness. If the oven is only mildly dirty, it can be cleaned again in only 75 minutes. This is all fully automatic and safe – and no chemicals are used.



## PROTOUCH



### AWARD-WINNING STAINLESS STEEL FOR EASY CLEANING

The award-winning ProTouch stainless steel surface has been specially treated to make cleaning an effortless task. Ugly finger marks become a thing of the past, and the exterior remains spotless longer after cleaning. Inside the oven, the full glass inner door, enamelled coating and tiltable grill facilitate for easier and more convenient cleaning.

 **COOL FRONT**



**NO HARM TO HANDS WITH  
CONSTANTLY COOL DOOR**

The either three- or four-layer glass door, equipped with a radial cooling fan, reduces heat radiation to contain additional heat inside the oven. Even during Pyrolytic Self-Clean, when the cavity heats up to 500°C, temperature of the cool door never exceeds 50°C. This not only keeps inquisitive children out of harm's way, but also protects nearby appliances.

**A-40% ENERGY CLASS**



**ENERGY SAVERS WITH DISTINCTION**

With low energy consumption, Bauknecht ovens carry up to A-40% energy efficiency label. This means they are 40% more environmentally-friendly than Class A ovens.

Ideal all-in-one appliance  
for modern kitchens



## BEST OF BOTH WORLDS: OVEN AND MICROWAVE IN ONE

Bauknecht's built-in compact ovens at a recess height of 45cm are extremely quick thanks to the combination of conventional oven functionality with microwave technology. Precisely for small kitchens, this offers an attractive alternative.

The ovens feature an enamelled interior, top and bottom heat as well as grill and fan functions – and are comfortable to control via the display. The integrated microwave function can be activated with traditional cooking methods as a helpful support, vastly shortening the cooking time. At the same time, consumers can enjoy crisp dishes – just like with a conventional oven.



What's more, the microwave function can be used on its own to defrost food or heat up meals. The design of these compact built-in ovens blends in seamlessly with the other 45cm built-in appliances from Bauknecht within the KOMFORT and KOSMOS lines.

# BCTMS9101PT

KOSMOS Oven with Pure Clean and Soft Closing



## The Bauknecht Oven Range

### Design

- KOSMOS line
- Pull-down opening
- Integrated handle

### Control

- LCD touch control
- ProCook user interface

### Cooking Features

- 13 Functions: Conventional, Grill, Turbo Grill, Forced Air, Convection Bake, Defrost, Keep Warm, Slow Cooking, Rising, Convenience, Maxi Cooking, Frozen Food, Eco-Forced Air
- Preset recipes: 30
- Meat Probe recipes: 7

### Caring Features

- Soft closing
- Fast preheating

- Favourite function
- Cool door (triple door glazing)
- Residual heat indicator
- 3 fully extended sliding grids
- Child lock

### Green Features

- PureClean
- Europe energy class A-40%
- No need to Pre-Heat
- Multi Level cooking
- Pro-touch surface coating
- Eco mode

### Specifications

- Capacity: 73L
- Number of shelf levels: 5
- Temperature setting: 50°C - 250°C
- Connected load: 3650W
- Spur unit: 20A
- Length of power cord: 1280mm

### Accessories supplied

- Meat probe: 1
- Standard wire shelf: 1
- Drip tray: 1
- Baking tray: 1
- Sliding runners: 3 pairs
- Cellulose cloth: 1

### Appliance Dimensions

- 595H x 595W x 565Dmm

### Cut out Dimensions

- 583H x 560W x 550Dmm

### Country of Origin

- Italy

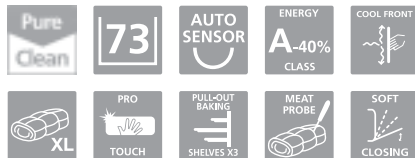

2012

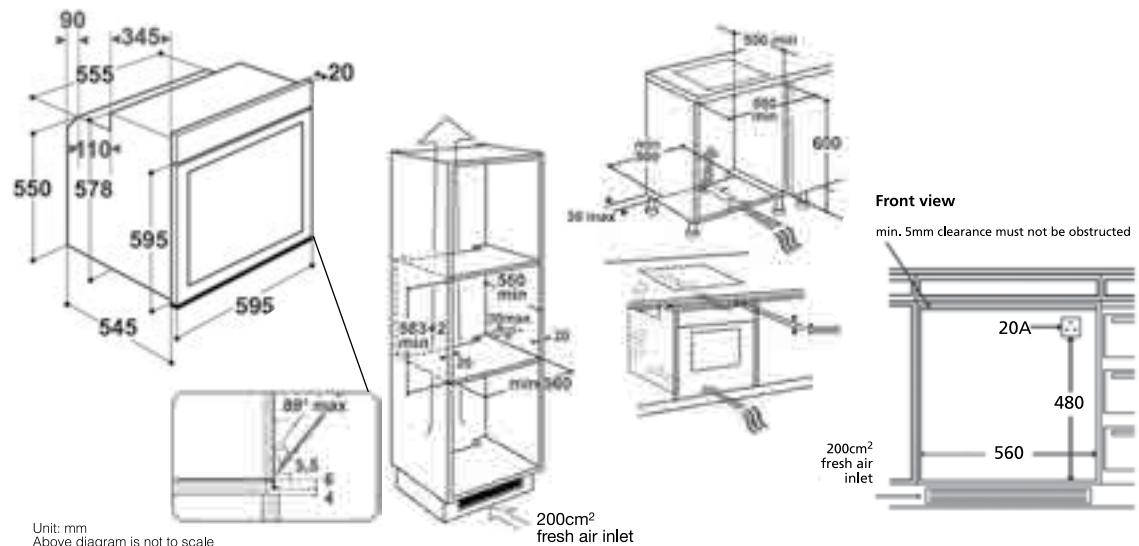

HK\$ 36,800



# BCVM8100/PT

KOMFORT Oven with Pure Clean



## The Bauknecht Oven Range

### Design

- KOMFORT line
- Pull-down opening
- Protruding handle

### Control

- Retractable knob control
- ProCook user interface

### Cooking Features

- 12 Functions: Conventional, Grill, Turbo Grill, Forced Air, Convection Bake, Defrost, Keep Warm, Slow Cooking, Rising, Convenience, Maxi Cooking, Frozen Food
- Preset recipes: 30

### Caring Features

- Favourite function
- Fast preheating
- Cool door (triple door glazing)
- Residual heat indicator
- 3 fully extended sliding grids
- Child lock

### Green Features

- Pure clean
- Europe energy class A-20%
- No need to preheat
- Multi-Level cooking
- ProTouch surface coating
- Eco mode

### Specifications

- Capacity: 73L
- Number of shelf levels: 5
- Temperature setting: 50°C - 250°C
- Connected load: 3650W
- Spur unit: 20A
- Length of power cord: 1000mm

### Accessories Supplied

- Standard wire shelf: 1
- Drip tray: 1
- Baking tray: 1
- Cellulose cloth: 1
- Cleaning sponge: 1

### Appliance Dimensions

- 595H x 595W x 565Dmm

### Cut out Dimensions

- 583H x 560W x 550Dmm

### Country Of Origin

- Italy

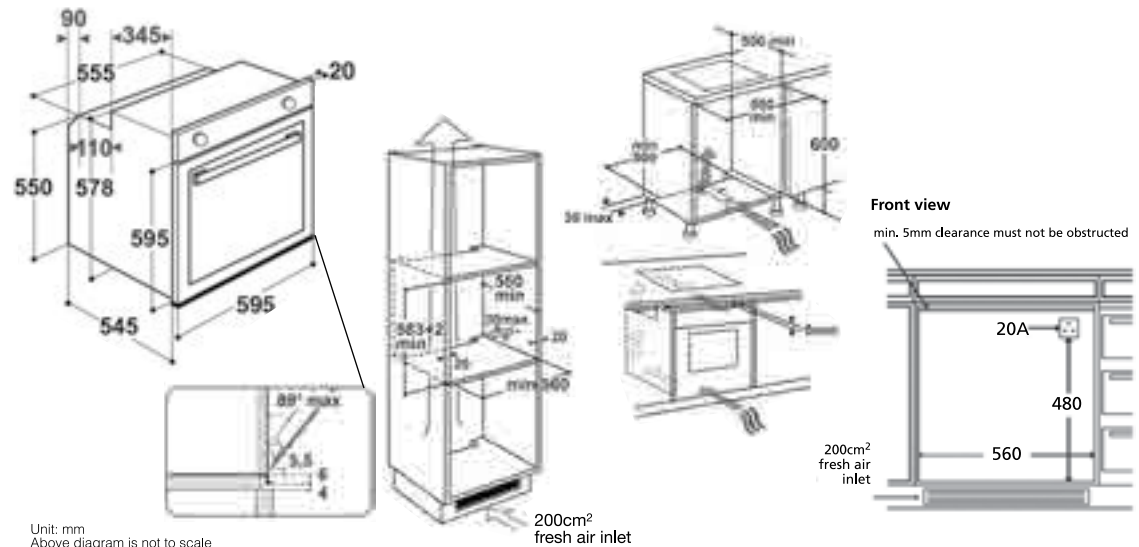
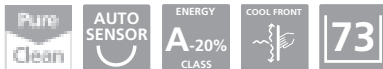

HK\$ 27,800

# BLPM8100/PT

KOMFORT Oven with Pyrolytic Self-Clean System



## The Bauknecht Oven Range

### Design

- KOMFORT line
- Pull-down opening
- Protruding handle

### Control

- Retractable knob control
- ProCook user interface

### Cooking Features

- 12 Functions: Conventional, Grill, Turbo Grill, Forced Air, Convection Bake, Defrost, Keep Warm, Slow Cooking, Rising, Convenience, Maxi Cooking, Frozen Food
- Preset recipes: 30

### Caring Features

- Favourite function
- Fast preheating
- Cool door (quadruple door glazing)
- Child lock

### Green Features

- Europe energy class A-20%
- No need to Pre-Heat
- Multi Level cooking
- ProTouch surface coating
- Pyrolytic Self-Clean
- Eco mode

### Specifications

- Capacity: 73L
- Number of shelf levels: 5
- Temperature settings: 50°C - 250°C
- Connected load: 3650W
- Spur unit: 20A
- Length of power cord: 1000mm

### Accessories Supplied

- Standard wire shelf: 1
- Drip tray: 1
- Baking tray: 1
- Sliding runners: 3 sets (complimentary)

### Appliance Dimensions

- 595H x 595W x 565Dmm

### Cut out Dimensions

- 583H x 560W x 550Dmm

### Country of Origin

- Italy

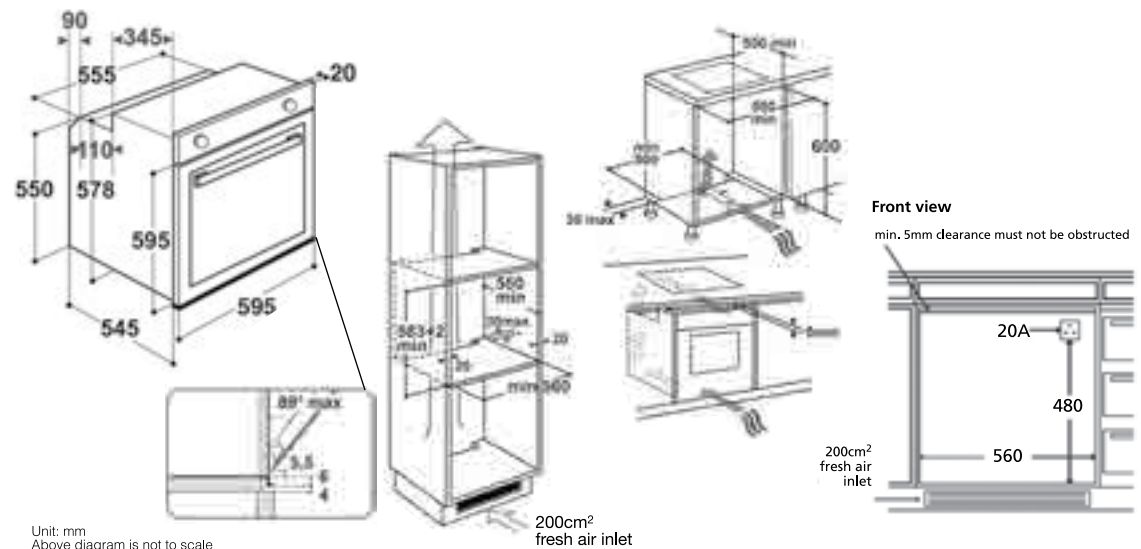

HK\$26,800



# BMES8145PT

KOMFORT Speed Oven with 40L Compartment



## Design

- KOMFORT line
- Pull-down opening
- Protruding handle

## Control

- Retractable knob control
- ProCook user interface

## Cooking Features

- Preset recipes
- 15 Functions: Dough Proving, Preheat, Conventional, Convection Bake, Convection Bake + Microwave, Grill, Grill + Microwave, Turbo Grill, Turbo Grill + Microwave, Keep Warm, Rapid Start, Auto Reheat, Manual Defrost, Auto Defrost

## Caring Features

- Short cut
- Selection of doneness
- Delayed start
- Timer
- Child lock

## Green Features

- Eco mode

## Specifications

- Capacity: 40L
- 7 Power levels
- Maximum temperature: 250°C
- Power output:
  - > Microwave: 850W
  - > Grill: 1600W
  - > Bottom heater: 1000W
- Connected load: 2800W
- Fuse spur unit: 16A

## Accessories Supplied

- Glass drip tray
- Wire shelf
- Baking tray

## Appliance Dimensions

- 455H x 595W x 560Dmm

## Cut Out Dimensions

- 450H x 560W x 550Dmm

## Country of Origin

- Europe

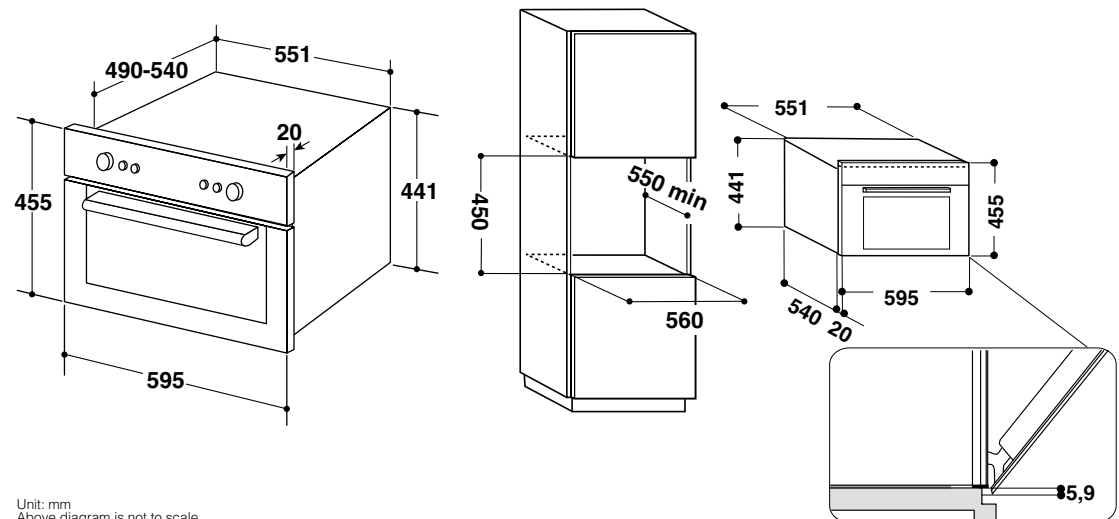
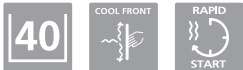

HK\$ 25,800

# BLVES8100/EW

KOMFORT Oven with White Glass Front and Soft Closing



## The Bauknecht Oven Range

### Design

- KOMFORT line
- Pull-down opening
- Protruding handle
- Soft closing

### Control

- Retractable knob control
- CleverCook user interface

### Cooking Features

- 13 Functions: Conventional, Grill, Turbo Grill, Forced Air, Convection Bake, Defrost, Keep Warm, Slow Cooking, Rising, Maxi Cooking, Bread, Pizza, Eco Forced Air

### Caring Features

- Favourite function
- Fast preheating
- Cool door (triple door glazing)
- Child lock
- Delayed start
- Residual heat indicator

### Green Features

- Europe energy class A-20%
- No need to Pre-Heat
- Multi-Level cooking
- Eco mode

### Specifications

- Capacity: 73L
- Number of shelf levels: 5
- Temperature setting: 50°C - 250°C
- Connected load: 3650W
- Spur unit: 20A
- Length of power cord: 1000mm

### Accessories Supplied

- Standard wire shelf: 1
- Drip tray: 1
- Baking tray: 1

### Appliance Dimensions

- 595H x 595W x 565Dmm

### Cut out Dimensions

- 583H x 560W x 550Dmm

### Country Of Origin

- Italy

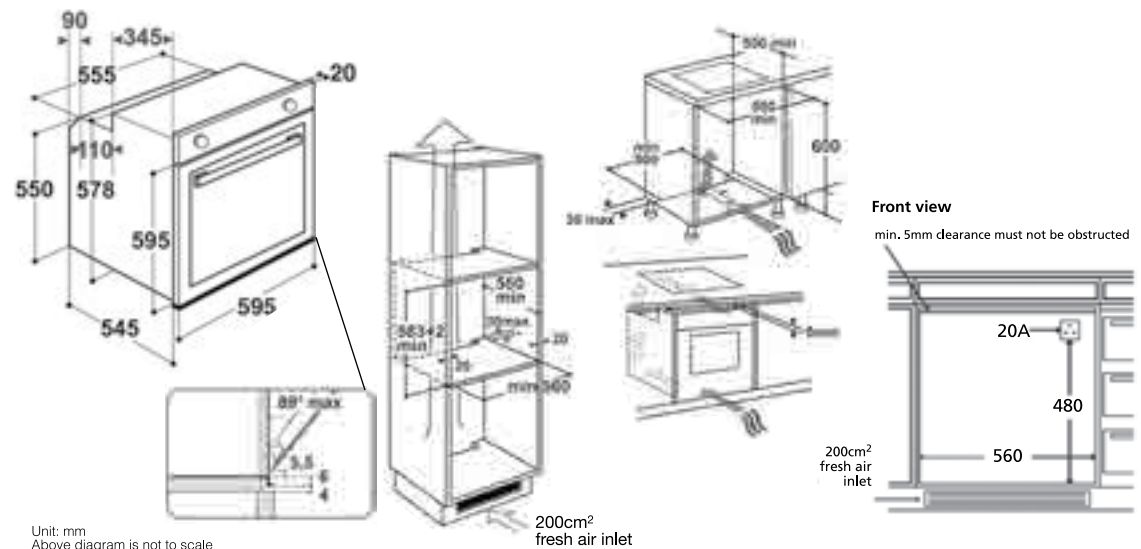

### Optional accessories:

- 1 pair of fully extendable sliding runners: \$499

HK\$ 12,800

# BLVES8100/PT

KOMFOFT Multi-function Oven with Soft Closing



## The Bauknecht Oven Range

### Design

- KOMFORT line
- Pull-down opening
- Protruding handle

### Control

- Retractable knob control
- CleverCook user interface

### Cooking Features

- 12 Functions: Conventional, Grill, Turbo Grill, Forced Air, Convection Bake, Defrost, Keep Warm, Slow Cooking, Rising, Maxi Cooking, Bread, Pizza

### Caring Features

- Soft closing
- Favourite function
- Fast preheating
- Cool door (triple door glazing)
- Child lock
- Delayed start
- Residual heat indicator

### Green Features

- Europe energy class A-20%
- No need to Pre-Heat
- Multi Level cooking
- Eco mode

### Specifications

- Capacity: 73L
- Number of shelf levels: 5
- Temperature setting: 50°C - 250°C
- Connected load: 3650W
- Spur unit: 20A
- Length of power cord: 1300mm

### Accessories Supplied

- Standard wire shelf: 1
- Drip tray: 1
- Baking tray: 1

### Appliance Dimensions

- 595H x 595W x 565Dmm

### Cut out Dimensions

- 583H x 560W x 550Dmm

### Country of Origin

- Italy



### Optional accessories:

- 1 pair of fully extendable sliding runners: \$499

HK\$ 10,800

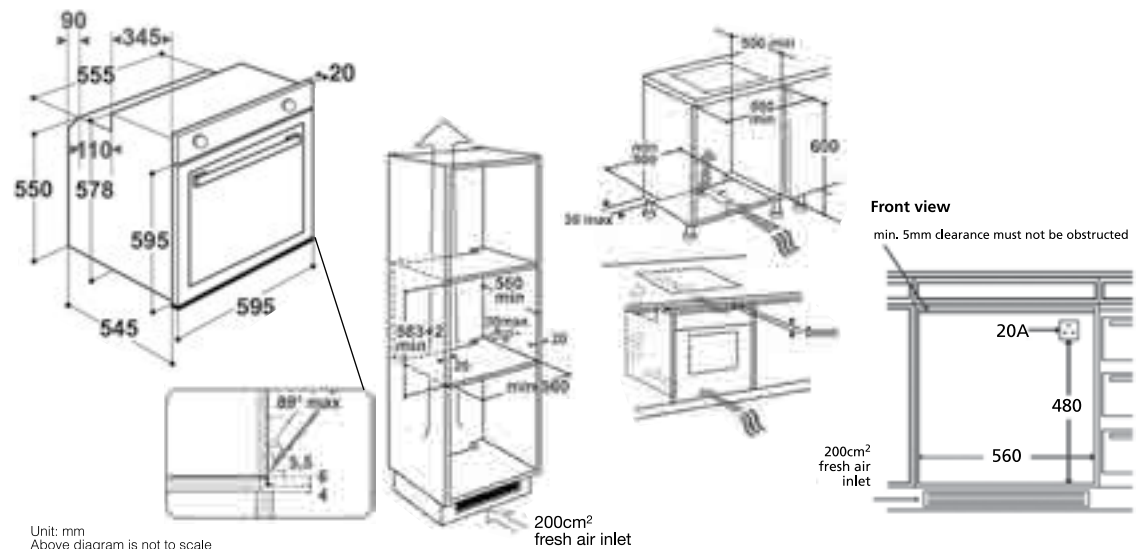

“The greatest gift  
you can give  
your family is a  
healthy you.”



# STEAMER

THE ULTIMATE IN HEALTHY COOKING

Steaming is ideal for the delicate preparation of meat, fish and vegetables. Meat and fish remain tender and succulent, while vegetables are tasty and crisp, retaining their natural colour and texture with all valuable nutrients preserved. As a testament to its superiority, Bauknecht's steamer was honoured as the best performing steamer by "Stiftung Warentest", an independent foundation for consumer rights in Germany.



# Steamer: Best recognisable cooking performance



## THE WINNER IN STEAMER PERFORMANCE

Bauknecht's steamer came first in a quality assessment of steamer performance in the latest "Stiftung Warentest" conducted in Germany. This renowned German consumer organisation analyses and compares products and services according to scientific and objective methods at independent institutes, and announces the results in its publications. 96% of Germans are familiar with the "Stiftung Warentest", and one-third make important purchase decisions based on products' test results.

Bauknecht's steamer earned valuable points in the test due to its optimal cooking results on different food types and cooking time. The testers were also impressed by the quick select function and its ease of use.





## MEAT PROBE

### STEAMING WITH FOOD PROBE FOR PROFESSIONAL RESULTS

Bauknecht's new range of steamers with food probe combines steaming with hot air to bring out the true taste and nutrients of foods. Offering simultaneous fan heating and steaming, the steamers deliver delicately cooked meat that is crispy and golden on the outside and juicy and succulent on the inside.

Equipped with numerous programmes that use the food probe to determine cooking time, the new steamers allow various challenging dishes, such as succulent delicious roast beef, to be easily prepared.





# Healthy eating at your fingertips

XXL  
 **XXL WATER TANK**



## LARGE WATER TANK FOR 100 MINUTES OF STEAMING

Thanks to the integrated 1.5L water tank, no separate water inlet is required. The extra large water tank supports continuous steaming of up to 100 minutes. The tank is also easy to clean and operate, helping you save time and effort.

 **PRESET RECIPES**



## 71 PRESET RECIPES FOR ULTIMATE HEALTHY COOKING

Bauknecht combi steamers offer up to 71 preset recipes which gives your maximize convenience to wealthy cooking experience. Ranging from meat and poultry to vegetables, pasta and dessert, you can virtually find everything to satisfy your appetite.





## YOGHURT MAKING



### MAKE YOUR OWN YOGHURT

The constant temperature maintained by the steamer allows the yoghurt to set. Making your own yoghurt doesn't get any easier than this.

You can also make your own preserved fruit with syrup and brined vegetables at home.



## DOUGH PROVING



### PERFECT HOMEMADE BREAD WITH PROVING AT 40°C

At a constant temperature of 40°C, the proving function makes the job much faster without bacterial contamination.



## DISINFECTION



### DISINFECTION PROGRAMME

Safeguard your baby's health without any hassle: let your Bauknecht steamer sterilise baby bottles or jars.

# ECTM9145/1PT

KOSMOS Combi Steamer with Meat Probe



## The Bauknecht Steamer Range

### Design

- KOSMOS line
- Pull-down opening
- Integrated handle

### Control

- LCD touch control
- ProCook user interface

### Cooking Features

- 6 Functions: Steam, Forced Air + Steam, Forced Air, Finishing, Reheat, Steam Defrost
- 4 Special functions: Rising, Preservation, Yoghurt, Disinfection
- Preset recipes: 71
- Meat Probe recipes: 8

### Caring Features

- Descaling
- Favourite function
- Reminder message

- Minute timer
- Buzzer at the end of cooking
- Child lock
- Delayed start

### Green Features

- Europe energy class A
- Steam Cleaning
- Multi Level cooking
- ProTouch surface coating
- Easy clean interior cavity
- Eco mode

### Specifications

- Capacity: 34L
- Temperature setting: 40°C - 230°C
- Connected load: 1450W
- Socket / Fuse spur unit: 13A
- Length of power cord: 1300mm

### Accessories Supplied

- Meat Probe: 1
- Water tank: 1.5L
- Baking & drip tray: 1
- Steam tray: 1
- Wire shelf: 1
- Sponge: 1
- Gastronorm Utensil Holder: 1

### Appliance Dimensions

- 455H x 595W x 515Dmm

### Cut Out Dimensions

- 460H x 560W x 550Dmm

### Country Of Origin

- Europe

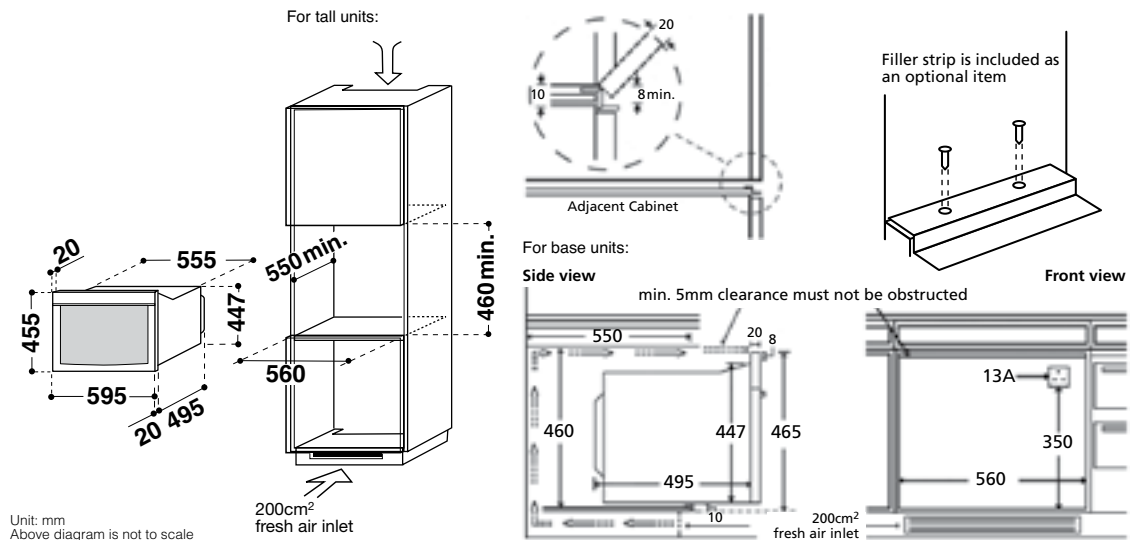

HK\$ 31,800

# ECTM8145EW

KOMFORT Combi Steamer with White Glass Front



## The Bauknecht Steamer Range

### Design

- KOMFORT line
- Pull-down opening
- Protruding handle

### Control

- Retractable knob control
- ProCook user interface

### Cooking Features

- 6 functions: Steam, Forced Air + Steam, Forced Air, Finishing, Reheat, Steam Defrost
- 4 Special functions: Rising, Preservation, Yoghurt, Disinfection
- Preset recipes: 71

### Caring Features

- Favourite function
- Reminder message
- Minute timer
- Buzzer at the end of cooking
- Child lock
- Delayed Start

### Green Features

- Europe energy class A
- Steam Cleaning
- Multi Level cooking
- Easy clean interior cavity
- Eco mode

### Specifications

- Capacity: 34L
- Temperature setting: 40°C - 230°C
- Connected load: 1450W
- Socket / Fuse spur unit: 13A
- Length of power cord: 1300mm

### Accessories Supplied

- Water tank: 1.5L
- Baking & drip tray: 1
- Steam tray: 1
- Standard wire shelf: 1
- Sponge: 1

### Appliance Dimensions

- 455H x 595W x 515Dmm (without handle)
- 455H x 595W x 563Dmm (with handle)

### Cut Out Dimensions

- 460H x 560W x 550Dmm

### Country of Origin

- Europe



For tall units:

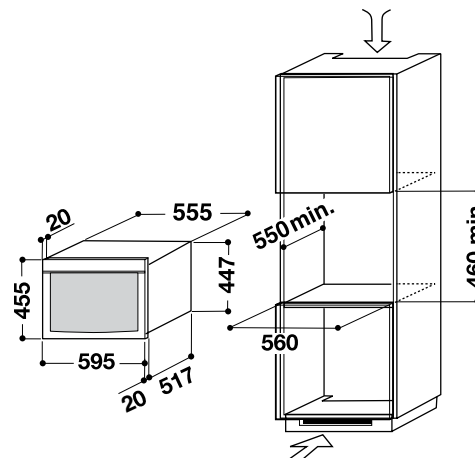

For base units:

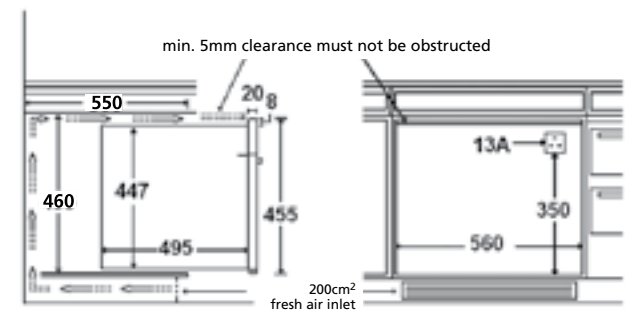

Unit: mm  
Above diagram is not to scale

HK\$ 29,800

# ESTM9145PT

KOSMOS Pure Steamer



## The Bauknecht Steamer Range

### Design

- KOSMOS line
- Pull-down opening
- Integrated handle

### Control

- LCD touch control
- ProCook user interface

### Cooking Features

- 4 Functions: Steam, Finishing, Reheat, Steam Defrost
- 4 Special functions: Rising, Preservation, Yoghurt, Disinfection
- Preset recipes: 30

### Caring Features

- Descaling
- Favourite function
- Minute timer
- Buzzer at the end of cooking
- Child lock
- Delayed Start

### Green Features

- Europe energy class A
- Multi Level cooking
- ProTouch surface
- Easy clean interior cavity
- Eco mode

### Specifications

- Capacity: 34L
- Temperature setting: 40°C - 100°C
- Connected load: 1450W
- Socket / Fuse spur unit: 13A
- Length of power cord: 1300mm

### Accessories Supplied

- Water tank: 1.5L
- Steam tray: 1
- Drip tray: 1
- Sponge: 1

### Appliance Dimensions

- 455H x 595W x 515Dmm

### Cut Out Dimensions

- 460H x 560W x 550Dmm

### Country Of Origin

- Europe

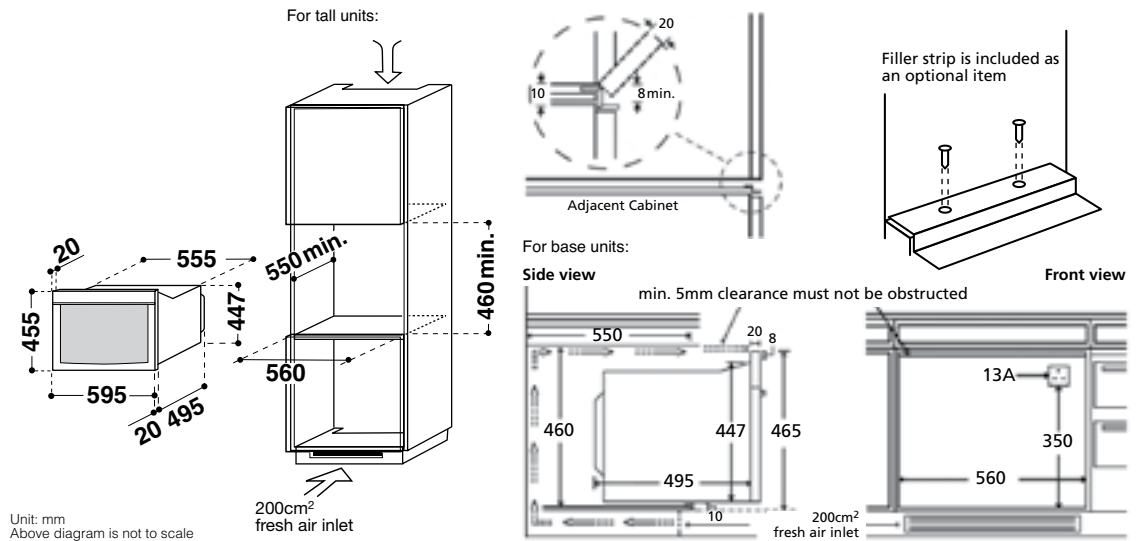

HK\$ 24,800

# ESTM8145PT

KOMFORT Pure Steamer



## The Bauknecht Steamer Range

### Design

- KOMFORT line
- Pull-down opening
- Protruding handle

### Control

- Retractable knob control
- ProCook user interface

### Cooking Features

- 4 Functions: Steam, Finishing, Reheat, Steam Defrost
- 4 Special functions: Rising, Preservation, Yoghurt, Disinfection
- Preset recipes: 30

### Caring Features

- Descaling
- Favourite function
- Minute timer
- Buzzer at the end of cooking
- Child lock
- Delayed Start

### Green Features

- Europe energy class A
- Multi Level cooking
- ProTouch surface
- Easy clean interior cavity
- Eco mode

### Specifications

- Capacity: 34L
- Temperature setting: 40°C - 100°C
- Connected load: 1450W
- Socket / Fuse spur unit: 13A
- Length of power cord: 1300mm

### Accessories Supplied

- Water tank: 1.5L
- Steam tray: 1
- Drip tray: 1
- Sponge: 1

### Appliance Dimensions

- 455H x 595W x 515Dmm (without handle)
- 455H x 595W x 563Dmm (with handle)

### Cut Out Dimensions

- 460H x 560W x 550Dmm

### Country of Origin

- Europe



For tall units:

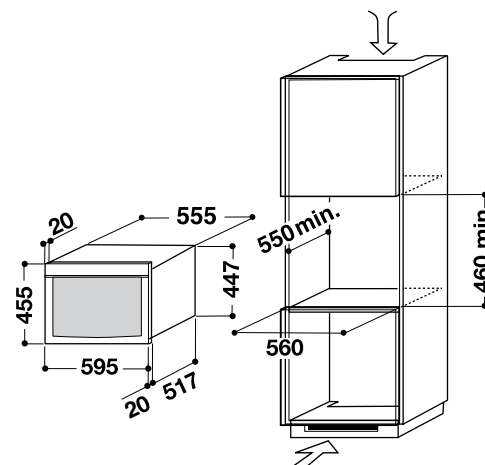

For base units:

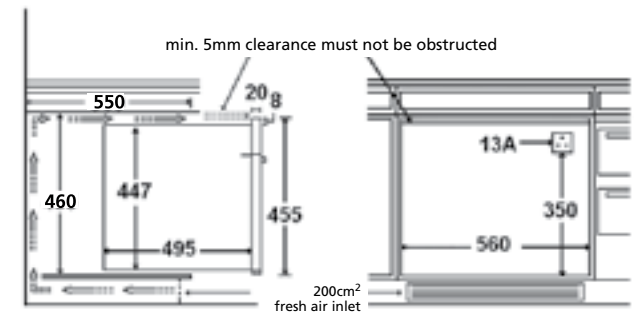

HK\$ 22,800

Unit: mm  
Above diagram is not to scale

“Fix your eyes on  
perfection and  
you make almost  
everything speed  
towards it.”





# MICROWAVE OVENS

TASTY FOOD IN SPLIT SECONDS

Bauknecht's microwave ovens share the same user interfaces with our oven range to offer convenient, intuitive control of your appliances.

Equipped with a patented 3D-system, together with a special crisp plate and the grill function, they guarantee an even result in and out, within a minimal time.



# Outstanding cooking results with maximum ease



## 3D-SYSTEM: CONSISTENT UNIFORMED RESULTS

Bauknecht's patented 3D-System combines dual heat emission with the reflection of microwaves to create even, three-dimensional distribution of microwaves throughout the cavity. The shade of the walls also allows for reflection of microwaves that adds a third dimension in heating depth.

Every part of the food receives the same amount of heat during cooking and defrosting, so you can rest assured that results will be perfect, every time.

What is more, you can heat two dishes in the microwave oven at the same time without switching them. Convenience, maximised.



## CRISP

### THE EXCLUSIVE CRISP FUNCTION FOR OUTSTANDING RESULTS

The Crisp function is the combination of a special Crisp plate, the 3D microwave distribution system and the grill. It ensures the same crispness as with a normal oven, but with a much shorter cooking time. The Crisp plate is heated up extremely quickly by microwaves coming from the lower part of the cavity. The grill heats up the upper part of the dish, while microwaves from the top of the cavity speed up the cooking process. As the Crisp plate does not heat up above 210°C, food is prevented from being overcooked.

#### Single Emission

In standard microwave ovens where the 3D-system is not present, microwaves are never 100% evenly distributed.

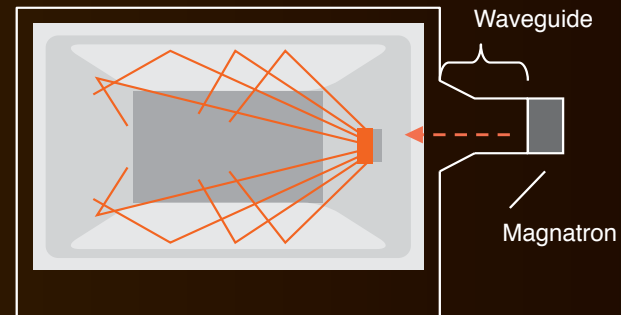

#### 3D Emission System

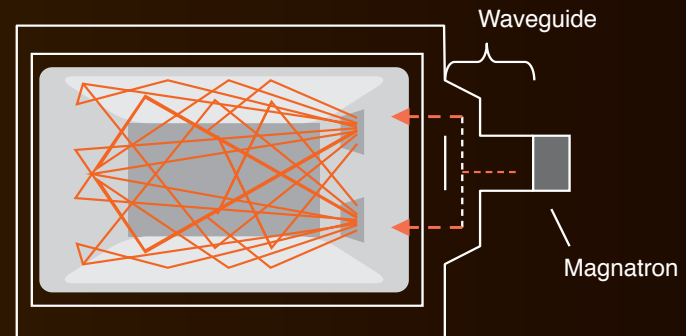

Microwaves are fed into the cavity from two entry points at a pre-determined time phase, thus creating a 3rd microwave field when bouncing from cavity walls.

# Function and aesthetic appeal in one offering

GREEN  
INTELLIGENCE™



## ADJUST TIME AND POWER AUTOMATICALLY

Thanks to the unique Crisp function and Green Intelligence Technology, Bauknecht microwave ovens are equipped with auto-reheat, crisp, and steam functions. You only need to select the food type – the oven does the rest by adjusting time and power based on the meal and humidity level of the food.

RAPID  
DEFROST



## PERFECT AND EVEN DEFROSTING IN A SHORT TIME

An exclusive defrosting system guarantees a perfect and even defrosting in a very quick time (2 minutes for 500g of meat vs. 14 minutes in a standard microwave oven), while preserving food quality.

Tailor-made defrost programmes adapt to different food class categories. You only need to key in the food weight, and the exclusive 3D microwave distribution system and special algorithms developed for each category ensure food is always defrosted evenly.

## SOFTENING & MELTING



### MELT BUTTER AND CHOCOLATE WITHOUT BURNING

With the softening & melting function, you can even process sensitive foods like butter, chocolate and ice cream without burning them and thus retaining the taste of the food.

## STEAM



### STEAMING FOR HEALTHY MEALS

Your Bauknecht microwave oven is equipped with Sensor Steam and Auto Steam functions that allow for really gentle and healthy cooking, ideal for vegetables, fish and rice because vitamins and minerals remain intact. The steamer pot withstands temperatures between 120°C and -40°C, and is dishwasher safe.

## INVERTER TECHNOLOGY



### CONSTANT MICROWAVE ENERGY FOR OPTIMISED COOKING RESULT

Your cooking should preserve tastes and nutrients. The innovative Bauknecht Inverter Technology produces constant microwave energy to prepare your food items evenly, carefully and in a controlled way. The inverter circuit situated at the top of the microwave takes up less space and allows for an optimised cooking area.

# Combining the best of both worlds





## MICROWAVE HOOD COMBINATION: DOUBLE THE POWER

The Bauknecht Microwave Hood Combination is the ideal solution for small kitchens, because it is a powerful extractor hood and a multi-functional microwave oven combined in one. The extractor hood is designed to manage the ambient air as well as extracted air, while the microwave oven delivers outstanding performance consistent with Bauknecht's standard microwave oven. The ProTouch stainless steel surface guarantees lasting cleanliness and an attractive design. Innovative functions such as the 3D System, Rapid Defrost and Crisp produce perfect cooking results within a short amount of time. This ingenious combination of extractor hood and microwave oven is, of course, well deserving of its recognition: it won the Plus X Award for innovation and the Kitchen Innovation Award.



# EMCHT91 45PT

KOSMOS 40L Microwave Oven



## The Microwave Oven Range

### Design

- KOSMOS line
- Pull-down opening
- Integrated handle

### Control

- LCD touch control
- ProCook user interface

### Cooking Features

- Inverter technology
- 16 Functions: Microwave, Grill, Grill + Microwave, Turbo Grill, Turbo Grill + Microwave, Crisp, Forced Air, Forced Air + Microwave, Quick Heat, Auto Crisp, Auto Reheat, Auto Steam, Rapid Defrost, Melt, Soften, Manual Defrost
- Preset recipes: 72
- 5 Levels of doneness
- 3D System

### Caring Features

- Residual heat indicator
- Shortcut function
- Minute timer
- Remind signal sound
- 24-hour LED clock
- Child lock

### Green Features

- ProTouch surface coating
- Eco mode

### Specifications

- Capacity: 40L
- 7 Power levels
- Maximum temperature setting: 250°C
- Power output:
  - > Microwave: 900W
  - > Grill: 1600W
  - > Forced air: 1200W

- Connected load: 2800W
- Socket / Fuse spur unit: 16A
- Length of power cord: 1250mm

### Accessories Supplied

- Turntable with support: 360mm diameter
- Wire rack
- Crisp plate with handle
- Cover plate
- Steamer
- Baking plate

### Appliance Dimensions

- 455H x 595W x 555Dmm

### Cut Out Dimensions

- 460H x 560W x 550Dmm

### Country Of Origin

- Europe

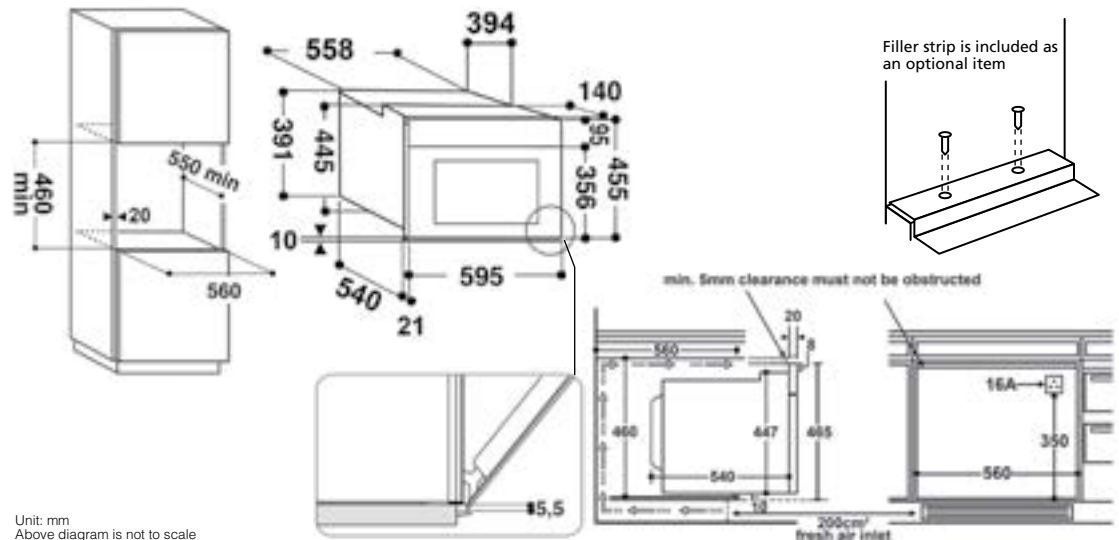
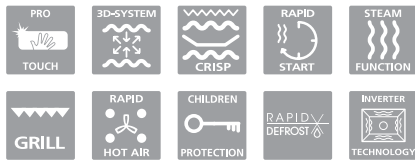

Unit: mm  
Above diagram is not to scale

HK\$ 17,800

# EMCHE81 45EW

KOMFORT 40L Microwave Oven with White Glass Front Panel



## The Microwave Oven Range

### Design

- KOMFORT line
- Pull-down opening
- Protruding handle

### Control

- Retractable knob control
- ProCook user interface

### Cooking Features

- 15 Functions: Microwave, Grill, Grill + Microwave, Turbo Grill + Microwave, Crisp, Forced Air, Forced Air + Microwave, Quick Heat, Auto Crisp, Auto Reheat, Auto Steam, Rapid Defrost, Auto Melt, Auto Soft, Manual Defrost
- Preset recipes: 72
- 5 Levels of doneness
- 3D System

### Caring Features

- Residual heat indicator
- Shortcut function

- Minute timer
- Key lock
- Remind signal sound
- 24-hour LED clock
- Child lock

### Green Features

- Eco mode

### Specifications

- Capacity: 40L
- 7 Power levels
- Maximum temperature setting: 250°C
- Power output:
  - > Microwave: 900W
  - > Grill: 1600W
  - > Forced air: 1200W
- Connected load: 2800W
- Socket / Fuse spur unit: 13A
- Length of power cord: 1250mm

### Accessories Supplied

- Turntable with support: 360mm diameter
- Wire rack
- Crisp plate with handle
- Steamer
- Baking plate

### Appliance Dimensions

- 455H x 595W x 565Dmm (without handle)
- 455H x 595W x 593Dmm (with handle)

### Cut Out Dimensions

- 460H x 560W x 550Dmm

### Country of Origin

- Europe



HK\$ 15,800

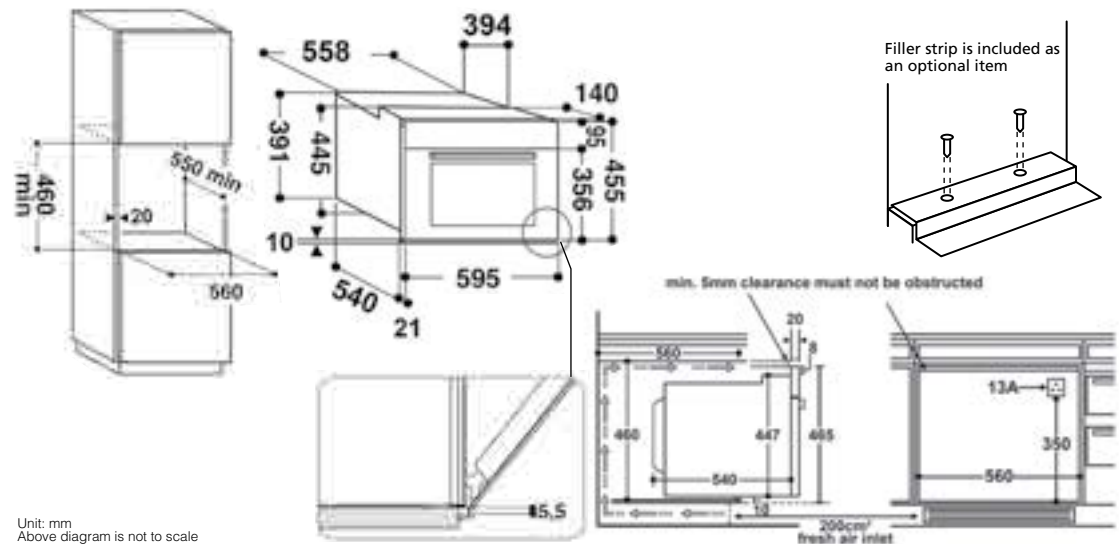

# EMCCE8138PT

KOMFORT 31L Microwave Oven



## The Microwave Oven Range

### Design

- KOMFORT line
- Pull-down opening
- Protruding handle

### Control

- Electronic button control
- CleverCook user interface

### Cooking Features

- Inverter technology
- 11 Functions: Microwave, Crisp, Auto Crisp, Grill, Grill + Microwave, Manual Defrost, Auto Reheat, Rapid Defrost, Auto Soft, Auto Melt, Auto Cook
- Preset recipes
- 5 level of doneness
- 3D System

### Caring Features

- Residual heat indicator
- Minute timer
- Remind signal sound
- 24 hour LED clock
- Child lock

### Green Features

- ProTouch surface coating
- Eco mode

### Specifications

- Capacity: 31L
- 8 Power levels
- Power output:
  - > Microwave: 1000W
  - > Grill: 800W
- Connected load: 1450W
- Socket / Fuse spur unit: 13A
- Length of power cord: 1250mm

### Accessories Supplied

- Turntable with support: 325mm diameter
- Crisp plate with handle

### Appliance Dimensions

- 385H x 595W x 493Dmm

### Cut Out Dimensions

- 380H x 560W x 550Dmm

### Country Of Origin

- Europe

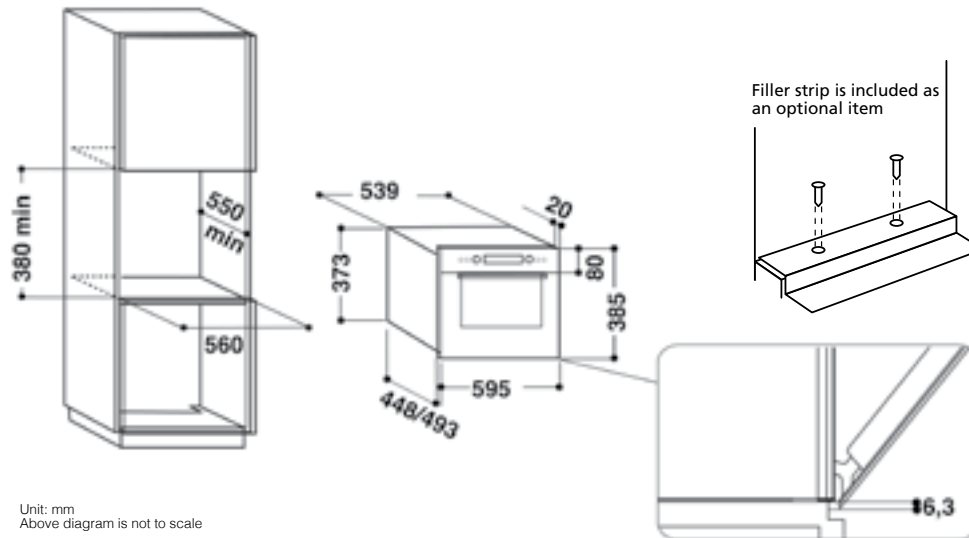

HK\$ 11,800

# EMCCE8138EW

KOMFORT 31L Microwave Oven with  
White Glass Front Panel



## Design

- KOMFORT line
- Pull-down opening
- Protruding handle

## Control

- Electronic button control
- CleveCook user interface

## Cooking Features

- Inverter technology
- 11 Functions: Microwave, Crisp, Auto Crisp, Grill, Grill + Microwave, Manual Defrost, Auto Reheat, Rapid Defrost, Auto Soft, Auto Melt, Auto Cook
- Preset recipes
- 5 level of doneness
- 3D System

## Caring Features

- Residual heat indicator
- Minute timer
- Remind signal sound
- 24 hour LED clock
- Child lock

## Green Features

- Eco mode

## Specifications

- Capacity: 31L
- 8 Power levels
- Power output:
  - > Microwave: 1000W
  - > Grill: 800W
- Connected load: 1450W
- Socket / Fuse spur unit: 13A
- Length of power cord: 1250mm

## Accessories Supplied

- Turntable with support: 325mm diameter
- Crisp plate with handle

## Appliance Dimensions

- 385H x 595W x 493Dmm

## Cut Out Dimensions

- 380H x 560W x 550Dmm

## Country Of Origin

- Europe

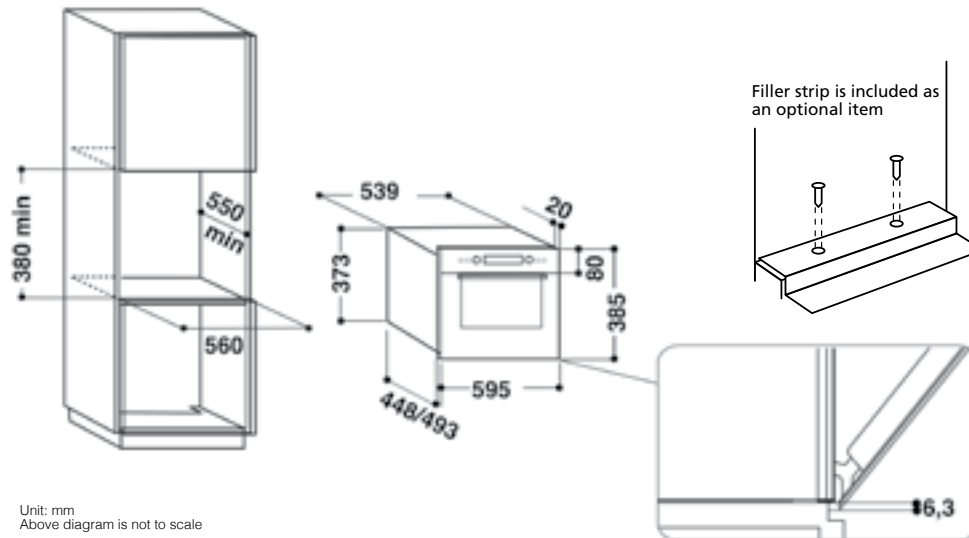

HK\$ 11,800

# EMWP9238WS

KOMFORT 22L Microwave Oven with  
White Glass Front Panel



## The Microwave Oven Range

### Design

- KOMFORT line
- Side opening

### Control

- Electronic button control

### Cooking Features

- 4 Functions: Microwave, Rapid Defrost, Rapid Start, Manual Defrost
- 3D System

### Caring Features

- Minute timer
- Remind signal sound
- 24 hour LED clock
- Child lock

### Green Features

- Eco mode

### Specifications

- Capacity: 22L
- 4 Power levels
- Power output:
  - > Microwave: 750W
- Connected load: 1300W
- Socket / Fuse spur unit: 13A
- Length of power cord: 1240mm

### Accessories Supplied

- Turntable with support: 250mm diameter

### Appliance Dimensions

- 380H x 595W x 321Dmm

### Cut Out Dimensions

- 365H x 560W x 300Dmm

### Country Of Origin

- Europe

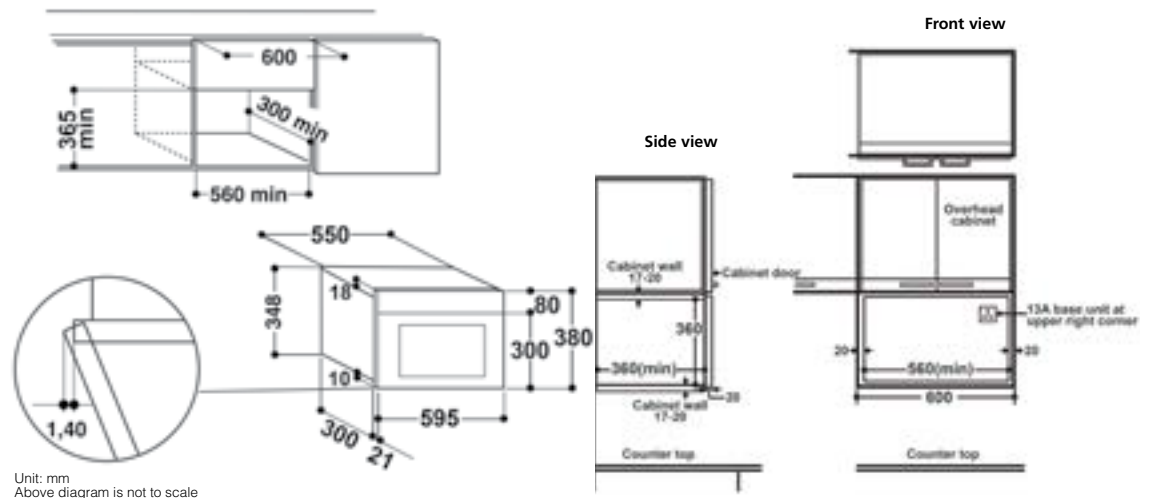

HK\$ 12,800



# EMWP9238PT

KOMFORT 22L Microwave Oven



## The Microwave Oven Range

### Design

- KOMFORT line
- Side opening

### Control

- Electronic button control

### Cooking Features

- 4 Functions: Microwave, Rapid Defrost, Rapid Start, Manual Defrost
- 3D System

### Caring Features

- Minute timer
- Remind signal sound
- 24-hour LED clock
- Child lock

### Green Features

- Eco mode

### Specifications

- Capacity: 22L
- 4 Power levels
- Power output:
  - > Microwave: 750W
- Connected load: 1300W
- Socket / Fuse spur unit: 13A
- Length of power cord: 1240mm

### Accessories Supplied

- Turntable with support: 250mm diameter

### Appliance Dimensions

- 380H x 595W x 321Dmm

### Cut Out Dimensions

- 365H x 560W x 300Dmm

### Country Of Origin

- Europe

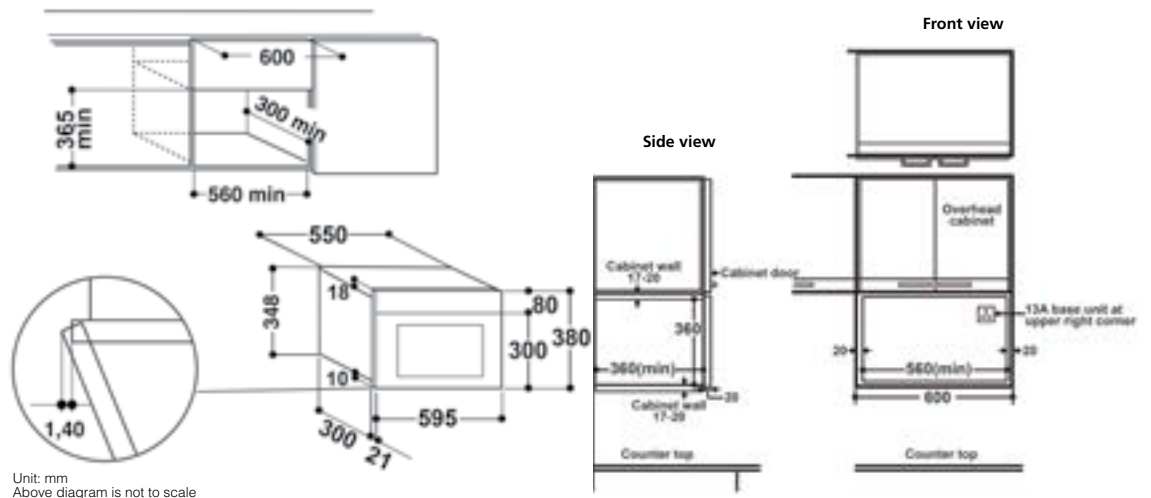
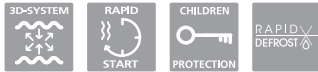

HK\$ 10,800

# MHC8822PT

KOMFORT Microwave Hood Combination



## The Microwave Oven Range

### Design

- KOMFORT line
- Side opening
- Protruding handle

### Control

- Electronic button control

### Cooking Features

- 5 Functions: Microwave, Crisp, Quartz Grill, Rapid Defrost, Rapid Start
- 3D System

### Caring Features

- Timer
- Remind signal sound
- 24-hour LED clock
- Child lock

### Green Features

- ProTouch surface coating
- 2 Halogen lamps on cookerhood

### Specifications In Microwave Oven

- Capacity: 22L
- 4 Power levels
- Power output:
  - > Microwave: 750W
  - > Grill: 700W

### Specifications In Hood

- Extraction flow: 360m<sup>3</sup> / hour
- Extraction or recirculation mode
- Number of speed: 3
- Metal grease filter
- Diameter of air duct: 120mm
- Connected load: 2100W
- Socket / Fuse spur unit: 13A
- Length of power cord: 800mm

### Accessories Supplied

- Turntable with support: 250mm diameter
- Cover plate
- Baby bottle holder

### Appliance Dimensions

- 588H x 598W x 460Dmm

### Cut Out Dimensions

- 650H x 600W x 320Dmm

### Country of Origin

- Europe

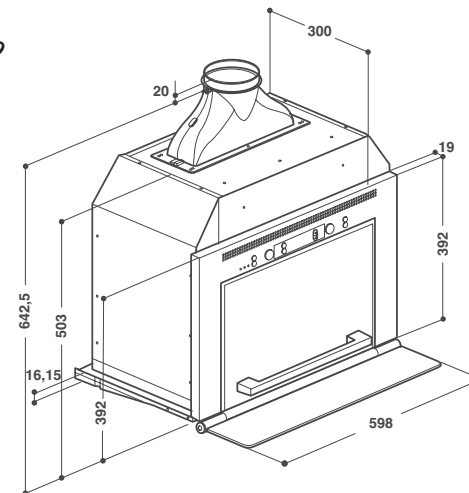
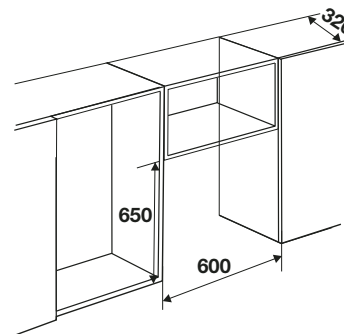

Unit: mm  
Above diagram is not to scale

HK\$ 16,800





“Love is like Silk,  
which is delicate,  
gentle, illuminating  
and soft.”



# COFFEE MAKERS & WARMER DRAWERS

COFFEE AT ITS BEST

Bauknecht's built-in automatic coffee maker really is an all-rounder: whether it's espresso, cappuccino or macchiato, the powerful 15 bar pump delivers perfect fresh brew from pre-ground coffee or beans.



# The perfect coffee experience



→  
AUTO **FULLY AUTOMATIC**  
←

## YOUR PERSONALISED FLAVOUR: THERE'S NEVER TOO MUCH OF IT

Bauknecht's fully automatic coffee machine offers personalisation of settings for strength of coffee, temperature and cup size. You can choose the amount of milk, coffee and froth according to your taste and pre-programme your favourite setting.

Prefer to get your dose of caffeine from tea? The coffee machine gives you hot water for that special cup too.



## GROUND BEANS AND POWDER SELECTION

Our coffee makers are designed to take 250g of your favourite coffee beans, or pre-ground coffee depending on your needs. You can also adjust the coffee grinder to prepare creamier coffee or coarser ground coffee. After running off the pre-set quantity of coffee, the machine automatically stops run-off and will then empty the coffee grounds into the grounds container. Even specialty coffees that require several steps can be prepared at the touch of a button.



# Ergonomic design that pleases in every way



## AWARD-WINNING STAINLESS STEEL FOR EASY CLEANING

Similar with our cooking range, the coffee maker is treated with the award-winning ProTouch stainless steel surface. The exterior of the coffee maker is protected from fingerprints, stains and scratches while cleaning is made exceptionally easy.



## EASY TO CLEAN AND STORE

The coffee maker comes with its own milk container. At the end of the brewing process, the jug can be easily removed and cleaned. If there is milk left, it can be returned to the fridge and installed back to the coffee machine when needed. It fuses coffee and milk automatically for the perfect cappuccino or caffè latte.



## RINSE CYCLE



## ENSURING EVERY CUP IS FRESH AND HOT

Every time the coffee machine is switched on, it runs an automatic preheat and rinse cycle to ensure that you always have a clean and fresh taste.

XXL



## XXL WATER TANK



## EXTRA LARGE WATER TANK

With a 1.8L water tank, you can brew up to 12 cups of coffee. This tank is located at the front of the machine for easy access during refilling.



## ACCESSORIES CONTAINER



## STORAGE FOR YOUR CUPS AND BEANS

The coffee machine is positioned on a sliding system so it can be pulled out easily from the front for filling beans or pre-grounded coffee. You can even use the side storage space for placing coffee beans, cups and stirrers.

# Maker and Drawer: A match made in heaven



## KEEP YOUR CUPS WARM IN A STYLISH WAY

In the world of coffee, temperature is crucial. While water temperature during the brewing process makes a world of difference, optimal drinking temperature adds the finishing touch to a sensational coffee experience. Now, your Bauknecht coffee maker has a perfect partner – our warming drawer that keeps your cups warm at 40°C - 60°C. Coffee excellence, guaranteed.

The coffee maker and warming drawer are made for each other not only in function but also in form. The 45cm high coffee maker and 15cm high warming drawer fit snugly into a 60cm tall cabinet to give your kitchen a neat and stylish look.



# KMT9145PT

KOSMOS Fully Automatic Coffee Maker



## Design

- KOSMOS Line

## Control

- Touch Control
- Automatic switch on / off

## Caring Features

- Text assisted display
- Personalised type
  - > Normal
  - > Cappuccino
  - > Caffè latte
- Personalised taste
  - > Extra mild
  - > Mild
  - > Normal
  - > Strong
  - > Extra strong

- Personalised size

- > Espresso
- > Small cup
- > Medium cup
- > Large cup
- > Mug
- Personalised amount of milk
- Adjustable coffee temperature
- Adjustable coffee grinder
- Coffee beans or ground coffee selection
- Electronic coffee and steam thermostat
- Automatic milk frothing jet
- Steam and hot water function
- Water level indicator
- Programmes for rinsing, cleaning and descaling

## Green Feature

- ProTouch surface

## Specifications

- Pump pressure: 15 bar
- Water container: 1.8L
- Milk jug capacity: 0.8L
- Removable drip tray
- Connected load: 1150W
- Socket / Fuse spur unit: 13A
- Length of power cord: 1250mm

## Appliance Dimensions

- 455H x 595W x 410Dmm

## Cut Out Dimensions

- 450H x 560W x 550Dmm

## Country Of Origin

- Italy

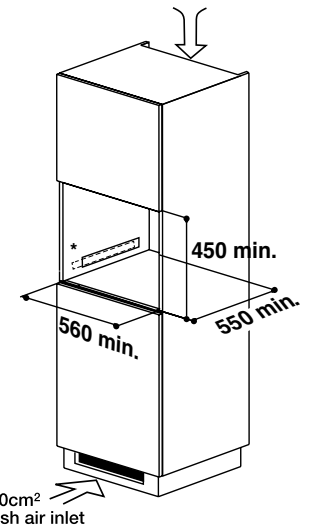
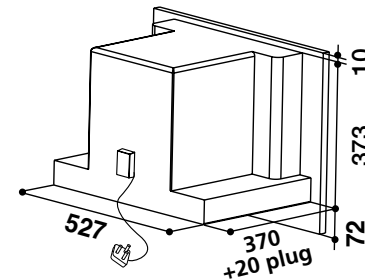
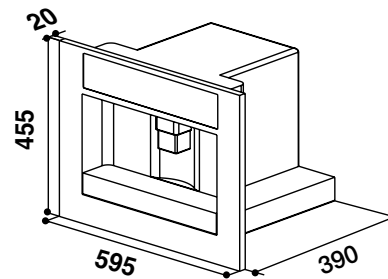

Unit: mm  
Above diagram is not to scale

HK\$ 29,800

# WD150/1PT

Warming Drawer



## Design

- Stainless steel panel

## Control

- Touch door opening
- Temperature setting: 40°C - 60°C

## Green Features

- ProTouch surface

## Specifications

- 6 Place settings
- Capacity: 20L
- Maximum load: 25kg
- Socket / Fuse spur unit: 13A
- Length of power cord: 1000mm

## Bauknecht Coffee Makers & Warmer Drawers

## Appliance Dimensions

- 143H x 595W x 551Dmm

## Country of Origin

- Italy

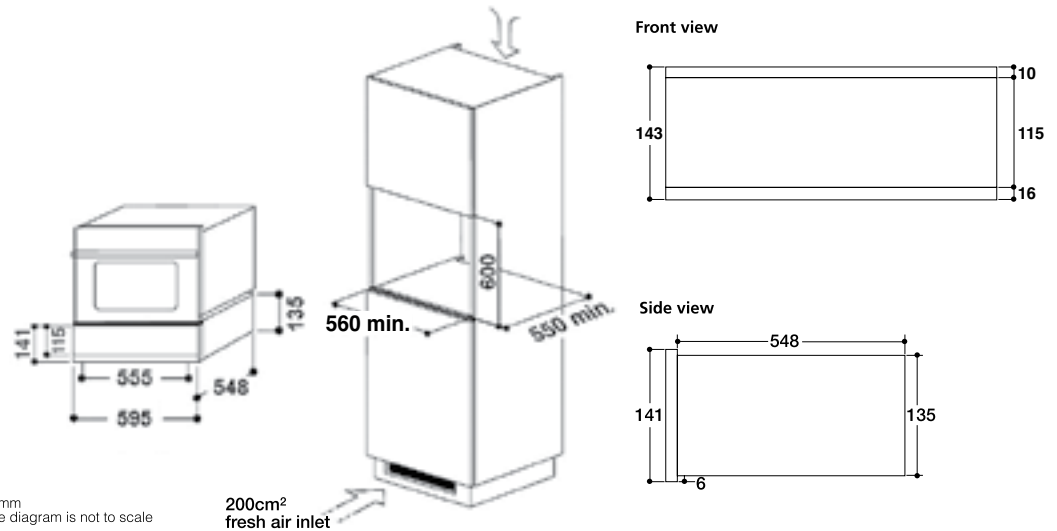

HK\$ 8,800



“The focus is what is right before you give it your best.”



# COOKERHOODS

## THE FOCAL POINT OF YOUR KITCHEN

Bauknecht's range of extractor cookerhoods combines stunning design and cutting-edge innovations to transform your kitchen into an idyllic space that is cleaner, quieter and most importantly, more environmentally friendly.

Whether it is a decorative hood for stylish fans, an island chimney that fits a luxurious kitchen, a wall mount chimney with a minimal and clean finish, or a telescopic hood that creates more room in the kitchen, there is a Bauknecht cookerhood for any and every cooking space.

# Enhancing the atmosphere in your kitchen, in every sense



## MORE THAN JUST AN ELEGANT FEATURE

The Bauknecht series of decorative hoods combine form with function. It features a mirrored front panel in white, and effortless swing-opening upon the swipe of an LED touch panel or with an intelligent remote control. These stylish cookerhoods enable extraction flow of up to 1,000m<sup>3</sup>/hr, so you can enjoy luxurious air cleaning from anywhere in the house.



## } ■ } BORDER SUCTION

### PERIMETER ASPIRATION: FRESH AIR, ALWAYS

The Bauknecht perimetric cookerhood produces uniform suction so that steam disappears quickly and thoroughly. At the same time, cooking vapours and fumes are evenly transferred to the filters along the outer edges of the hood bottom rather than directly through it, so that more of the grease can be collected. Additionally, the filters are ingeniously concealed so that noise levels are substantially reduced.

# Easy to clean with thoughtful green features



LED



## LONGER LIFETIME ON LESSER ENERGY CONSUMPTION

Small things can make a huge difference. With energy consumption of 3W (compared with 20W for halogen lamps and 40W for incandescent lamps), the small LED lamp can help you achieve energy savings of up to 85%. Its lifespan, meanwhile, is 20 times longer than halogen lamps.



WASHABLE FILTER



## EASY TO CLEAN FILTERS

The grease filters in Bauknecht hoods are made of rust-proof metal and can be easily removed for cleaning. You can use the filters over and over again, while your hood stays clean and hygienic.

 **SOUND PROOF MOTOR**



**REDUCED NOISE FOR A QUIETER KITCHEN**

Bauknecht's extractor hoods feature a sound proof motor that eliminates turbulence, while the unique phono-absorbing material installed inside the chimney absorbs noise during the extraction process, guaranteeing a pleasant and enjoyable cooking experience.

 **DELAY OFF**

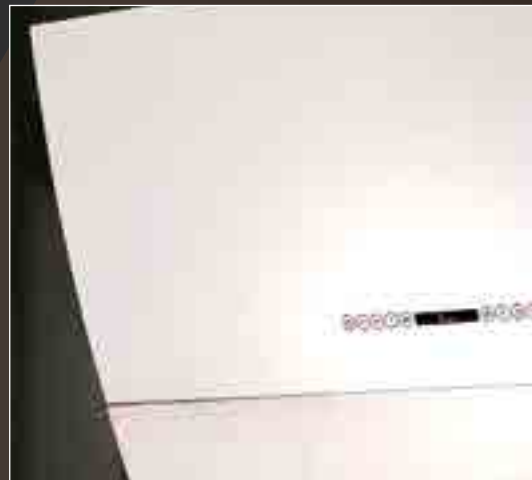

**CLEAN AND FRESH AIR EVEN YOU ARE AWAY FROM THE KITCHEN**

Our decorative hood is equipped with a delay-off function, so you can leave your hood switched on after intensive cooking, and just walk away and leave the cleaning job to the hood.

 **INTENSIVE**



**ADDITIONAL BOOST TO INCREASE EXTRACTION POWER**

When you are stir-frying or deep-frying, turn on the intensive mode to temporarily increase the extraction level of your Bauknecht cookerhood. This way, you can be assured that your kitchen will always be free of unpleasant odours. Extraction level has been programmed to return to a lower level after a few minutes.

# DWGR8410EW

Decorative Cookerhood with White Mirror Glass Front Panel



Bauknecht Cookerhood Range

## Design

- Decorative wall mounted type
- 900mm width
- White mirror front panel

## Control

- Remote control
- Top swing open with LED glass touch control
- Number of speeds: 4 + 1 intensive

## Caring Features

- Grease filter saturation indicator
- Delay off function
- 24-hour anti-kitchen pollution
- Control lock
- Cassettes dishwasher safe

## Green Feature

- LED lamps: 2 x 20W

## Specifications

- Extraction or recirculation mode
- Extraction flow (unrestricted): 1000m<sup>3</sup> / hour
- Diameter of air duct: 150mm / 120mm
- Socket / Fuse spur unit: 13A

## Accessories Supplied

- Remote control

## Optional Accessories

- Charcoal filter kit

## Appliance Dimensions

- 1145-1625H x 900W x 350Dmm

## Country Of Origin

- Italy

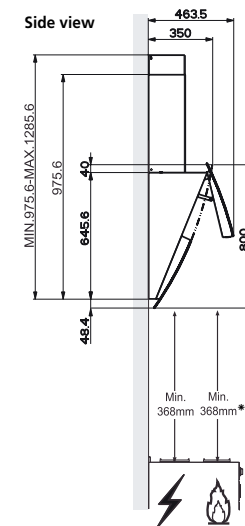
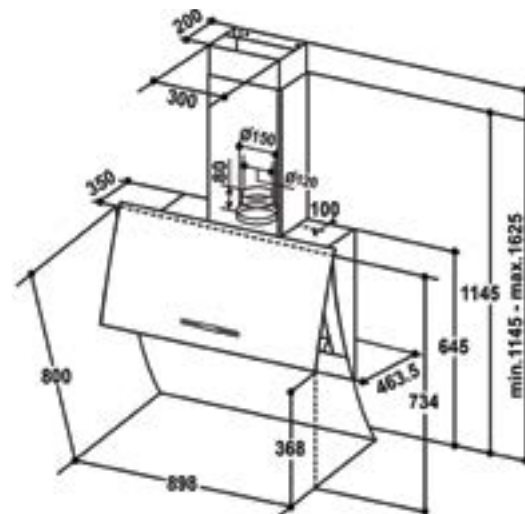

HK\$ 34,800

Unit: mm  
Above diagram is not to scale  
\*From upper edge of pan support



# CPB1200

120cm Wall Mounted Chimney Cookerhood



## Bauknecht Cookerhood Range

### Design

- Wall mounted type
- 1200mm width
- Stainless steel front panel

### Control

- Electric soft button control
- Number of speeds: 4 + 1 intensive

### Filter Features

- Washable aluminium filter
- Perimeter aspiration

### Caring Features

- Delay off function
- 24-hour function
- Dimmer lighting
- Filter saturation indicator

### Green Features

- LED lighting
- Sound proof motor

### Specifications

- Extraction or recirculation mode
- Extraction flow (unrestricted): 1000m<sup>3</sup> / hour
- Diameter of air duct: 150mm
- Socket / Fuse spur unit: 13A
- Length of power cord: 1000mm

### Appliance Dimensions

- 600-950H x 1198W x 490Dmm

### Country Of Origin

- Italy

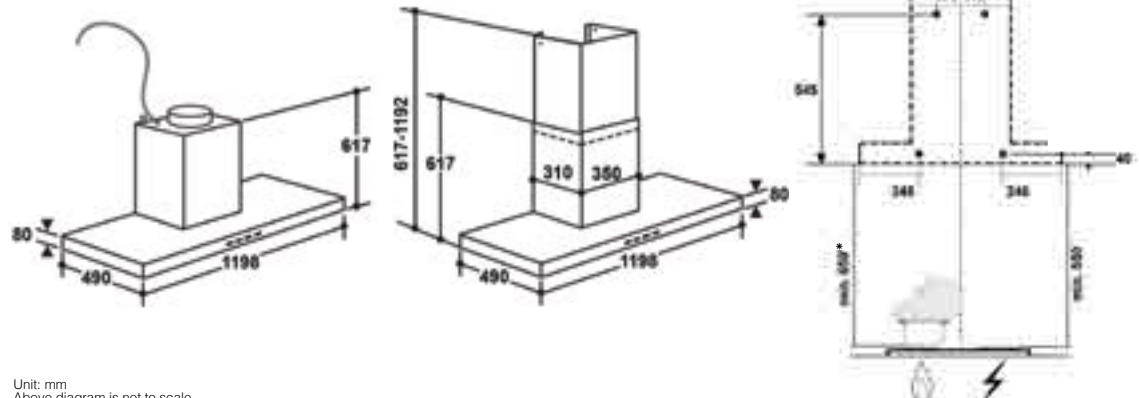

Unit: mm  
Above diagram is not to scale  
\*From upper edge of pan support

HK\$ 23,800

# SPB 1 200

120cm Wall Mounted Chimney Cookerhood



## Bauknecht Cookerhood Range

### Design

- Wall mounted type
- 1200mm width

### Control

- Electronic soft touch control
- Number of speeds: 3 + 1 intensive

### Filter Feature

- Washable aluminum filter

### Green Features

- LED lighting
- Sound proof motor

### Specifications

- Extraction or recirculation mode
- Extraction flow (unrestricted):  
1000m<sup>3</sup> / hour
- Diameter of air duct: 150mm
- Socket / Fuse spur unit: 13A

### Appliance Dimensions

- 600-950H x 1198W x 470Dmm

### Country Of Origin

- Italy

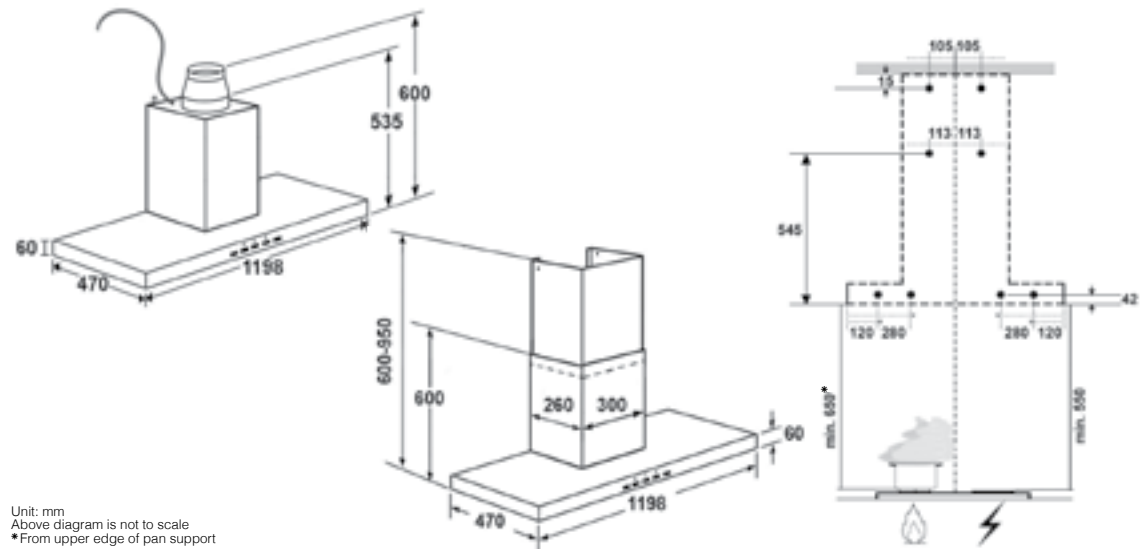

Unit: mm  
Above diagram is not to scale  
\* From upper edge of pan support

HK\$ 21,800

# CPT1000

90cm Wall Mounted Chimney Cookerhood  
with Touch Control



## Design

- Wall mounted type
- 900mm width
- Black glass front panel

## Control

- Touch control
- Number of speeds: 4 + 1 intensive

## Filter Features

- Washable aluminium filter
- Perimeter aspiration

## Caring Features

- Delay off function
- 24-hour function
- Dimmer lighting
- Filter saturation indicator

## Green Features

- LED lighting
- Sound proof motor

## Specifications

- Extraction or recirculation mode
- Extraction flow (unrestricted): 1000m<sup>3</sup> / hour
- Diameter of air duct: 150mm
- Socket / Fuse spur unit: 13A
- Length of power cord: 1200mm

## Appliance Dimensions

- 600-950H x 898W x 490Dmm

## Country Of Origin

- Italy

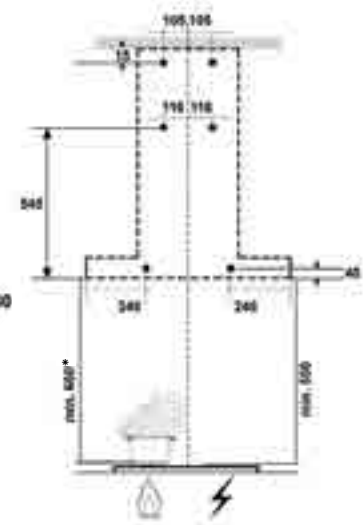
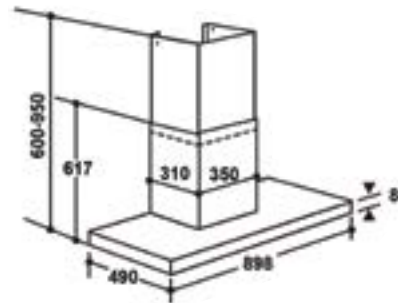
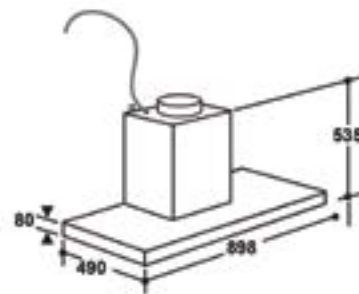
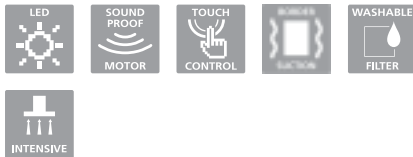

HK\$ 19,800

Unit: mm  
Above diagram is not to scale  
\*From upper edge of pan support

# DBTR91 90IXL

90cm Chimney Cookerhood



## Bauknecht Cookerhood Range

### Design

- Wall mounted type
- 900mm width
- Black Glass front panel

### Control

- Touch control
- Number of Speed: 4 + 1 intensive

### Caring Features

- Washable aluminium filter
- Perimeter aspiration
- Delay off function

### Green Features

- LED lighting
- Anti-scratch iXelium™ coating

### Specifications

- Extraction or recirculation mode
- Extraction flow(IEC61591): 731m<sup>3</sup>/hr
- Diameter of air duct: 150mm
- Socket / Use spur unit: 13A
- Length of power cord: 1000mm

### Appliance Dimensions

- 630-1035H x 898W x 500Dmm

### Country of Origin

- Europe

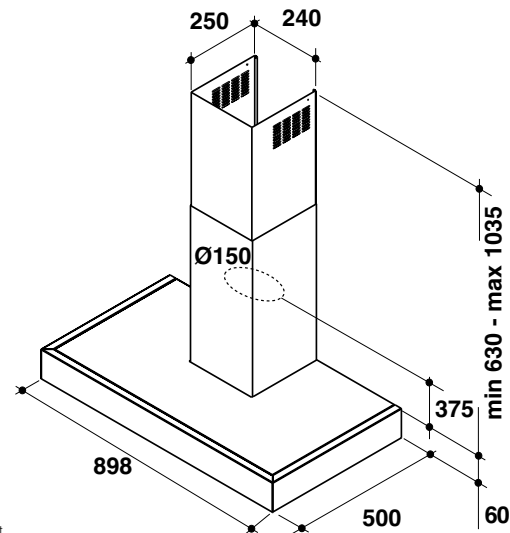

Unit: mm  
Above diagram is not to scale  
\* From upper edge of pan support

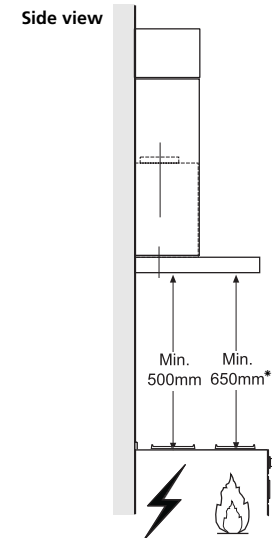

HK\$ 14,800

# DNHV1000

90cm Telescopic Cookerhood



## Bauknecht Cookerhood Range

### Design

- Telescopic type
- 900mm width

### Control

- Slider control
- Number of speeds: 3

### Filter Feature

- Washable aluminium filter

### Green Feature

- Halogen lamps: 2 x 20W

### Specifications

- Extraction or recirculation mode
- Extraction flow (unrestricted):  
950m<sup>3</sup> / hour
- Diameter of air duct: 150mm
- Socket / Fuse spur unit: 13A

### Appliance Dimensions

- 260H x 898W x 302-454Dmm

### Cut Out Dimensions

- 600H x 805W x 264Dmm

### Country Of Origin

- Europe

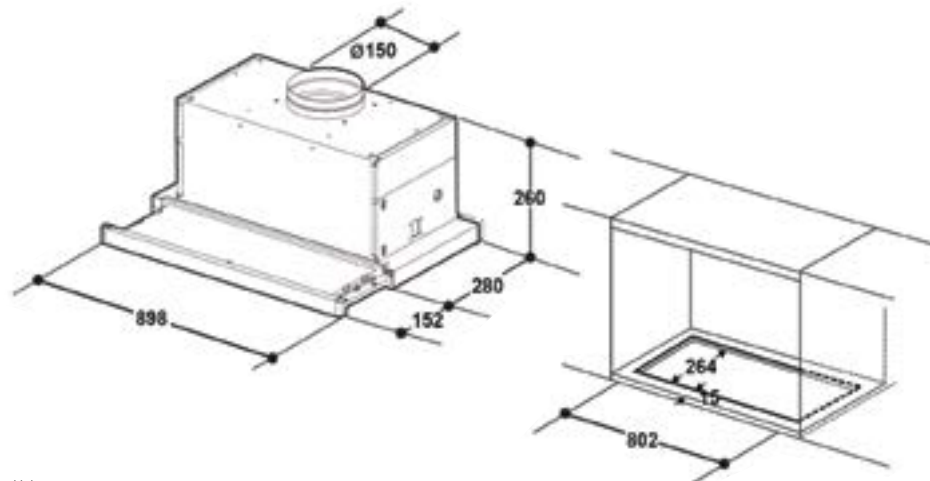

Unit: mm  
Above diagram is not to scale  
\*From upper edge of pan support

Side view

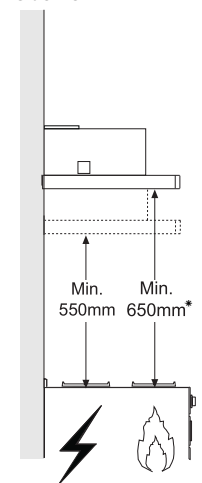

HK\$ 9,800

“Stay committed  
to your decisions,  
but stay flexible in  
your approach.”



# HOBS

THE INTELLIGENCE AND FLEXIBILITY TO MAKE COOKING SIMPLER

The Bauknecht induction hob range has been designed to give you more cooking pleasure. With the Flexi-zone function, it gives you the freedom to organize your cooking area to suit your requirements. Innovative patented technologies deliver powerful induction heating, while user-friendly controls and features make cooking on the hob unbelievably easy and enjoyable.

All of these properties secured the Flexi-zone hobs the highest scores, earning them the Best of the Best Award 2014 in gold.





# Perfect solutions to optimise your time



## NO OVERFLOW AND SAVES 30% ENERGY

A special sensor senses the temperature of the pot and boiling peak. It provides an acoustic feedback when water is boiled, and reduces the power level to keep the boiling temperature constant so the water level is under control. If the temperature of the pot gets too high, the hob automatically switches off. This helps you to save up to 30% energy, and prevents over-boiling and drying out of the pot.



## FLEXI-ZONE



## ACCOMMODATES A WIDER RANGE OF COOKWARE

With the Flexi-zone function, you can combine two cooking zones and manage them as one. The Flexi-zone recognises the shape of the pot or pan you are using and delivers powerful, uniform heating to oval, rectangular and elongated pans.

You can select 2 separate zones independently, with different power levels in each area. Or if you need to, merge the 2 areas into a bigger one to reach an even cooking result over a larger surface.

# Intelligent cooking, perfect results

## POWER BOOSTER



### MAXIMUM HEAT IN JUST 4 MINUTES

Bauknecht hobs feature an up to 5kW booster that can be activated when fast cooking/ boiling is needed to give maximum heat in just 4 minutes at 250°C. Thanks to better evenness in heating distribution, the boiling time is speed up.

## SLIDER



### ADJUST COOKING TEMPERATURE WITH A GENTLE SLIDE

Touch control user interface with slider function gives you maximum convenience to adjust the cooking temperature. After activating the desired induction zone, the induction power can be manually regulated with the new user-friendly touch-sensitive slider: a gentle sliding of the finger over the scale enables smooth control of the hob's temperature.

SCHOTT CERAN®



### WORLD'S ONLY GLASS MADE WITHOUT TOXIC MATERIALS

All Bauknecht induction hobs are fitted with SCHOTT CERAN® glass ceramic surfaces. These are the only glass ceramic tops produced without the use of heavy metal arsenic and antimony – yet another way Bauknecht helps you to contribute to environmental protection.



## HIGH ENERGY EFFICIENCY OF UP TO 90%

Induction heating has an energy efficiency of 90%, compared with 65% for radiant heating and 52% for gas heating. Also, an induction cooking surface cools in 6 minutes, substantially quicker than gas (14 minutes), and radiant hobs (25 minutes), and reacts much faster in changing heating power than radiant hobs. All these add up to significant reduction of energy consumption.



## PRECISE TEMPERATURE CONTROL FOR A HUGE VARIETY OF COOKING TASKS

The induction hobs are equipped with Bauknecht's own state-of-the-art technology, which allows you to use a wider range of cooking temperatures compared to a standard hob. The temperature varies from very low to extremely high, giving the right heat for every recipe: chocolate melting at 35°C; keeping warm at 60-70°C; fast boiling at 100°C.



## ALWAYS ADAPTS TO YOUR NEEDS

The new user interface enables a wide selection of convenient cooking modes for daily preparation of food, with special functions like melting and simmering. To use one of the two automatic functions, the desired zone must be activated before the desired automatic function, melt or simmer. The power is automatically maintained at the right level.

Mix and match with style



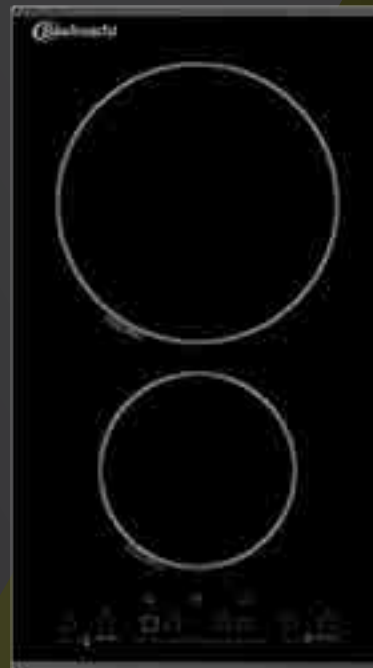

## MORE SPACE, MORE FLEXIBILITY

Bauknecht also offers domino hobs so that you can mix and match different combinations according to your kitchen size and needs. Thanks to the Sabaf® burner from Italy, our single wok burner provides up to 5.2kW, which is more than hot enough for those who enjoy Chinese stir-fried dishes.

# ESMIF8740IN

4-head Induction with Flexi-Zone



## Bauknecht Hobs Range

### Design

- Full glass with LED display

### Control

- Slider touch control
- Power levels: 9

### Cooking Features

- Automatic programme
- Melting
- Simmering
- Flexi-zone

### Caring Features

- Auto-sensor
- Timer function
- Acoustic minute minder
- Residual heat indicator
- Pause function
- Child lock
- Anti-spill control
- Safety switch off feature
- Automatic pot detection

### Green Feature

- SCHOTT CERAN® glass

### Specifications

- Spur unit: 32A
- Length of power cord: 1000mm
- Cooking zones diameter/outputs:

### Appliance Dimensions

- 52H x 775W x 515Dmm

### Cut Out Dimensions

- 750W x 490Dmm

### Country Of Origin

- Italy

Zone	Output (W)	Output with booster (W)	Diameter (mm)
Rear left	1850	2500	180/ 230
Front left	1850	2500	180/ 230
Middle	1400	1800	145
Right	2300	3700	280

Total power (max): 7,400W



### Thickness Of Worktop

- 20-50mm

### Minimum Ventilation Space

- Minimum 50mm back and minimum 100mm side clearance from glass edges of hob to its surrounding non-combustible materials
- Minimum 20mm / 100mm clearance from base trap of hob to washer / drawer (non-combustible materials)

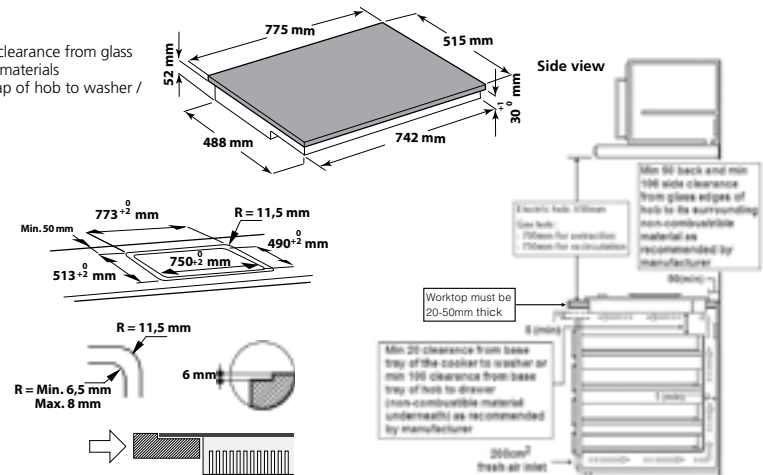
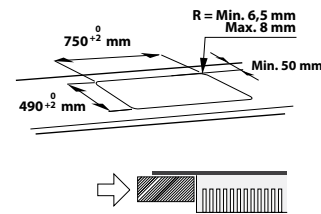

Unit: mm  
Above diagram is not to scale

HK\$ 29,800



# ESPIF8640IN

4-head Induction with Flexi-Zone



## Design

- Full glass with LED display

## Control

- Slider touch control
- Power levels: 9

## Cooking Features

- Automatic programme
- Melting
- Simmering

## Caring Features

- Auto-sensor
- Timer function
- Acoustic minute minder
- Residual heat indicator
- Pause function
- Child lock
- Anti-spill control
- Safety switch off feature
- Automatic pot detection

## Green Feature

- SCHOTT CERAN® glass

## Specifications

- Spur unit: 32A
- Length of power cord: 1000mm
- Cooking zones diameter/outputs:

## Appliance Dimensions

- 52H x 585W x 515Dmm

## Cut Out Dimensions

- 560W x 490Dmm

## Country Of Origin

- Italy

Zone	Output (W)	Output with booster (W)	Diameter (mm)
Rear left	1850	3200	180
Front left	1850	2500	180
Middle	2300	4200	240
Right	1400	1800	145

Total power (max): 7,400W



## Thickness Of Worktop

- 20-50mm

## Minimum Ventilation Space

- Minimum 50mm back and minimum 100mm side clearance from glass edges of hob to its surrounding non-combustible materials
- Minimum 20mm / 100mm clearance from base trap of hob to washer / drawer (non-combustible materials)

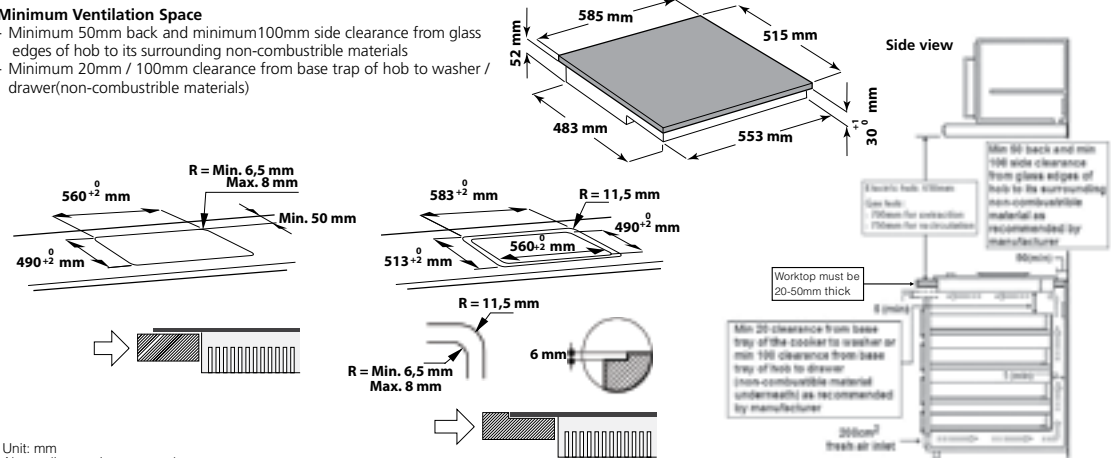

HK\$ 23,800

Unit: mm  
Above diagram is not to scale

# ETI6260IN

Domino 2-head Induction Hob with Touch Control



## Bauknecht Hobs Range

### Design

- Full glass with LED display

### Control

- Touch control

### Cooking Feature

- Timer function

### Caring Features

- Safety switch off feature
- Acoustic minute minder
- Automatic pot detection
- Child lock
- Anti-spill control

### Green Feature

- SCHOTT CERAN® glass

### Optional Accessories

- Connecting rail

### Specifications

- Spur unit: 20A
- Length of power cord: 1000mm
- Cooking zones diameter/outputs:

### Appliance Dimensions

- 58H x 288W x 515Dmm

### Cut Out Dimensions

- 275W x 495Dmm

### Country Of Origin

- Italy

Zone	Output (W)	Diameter (mm)
Front	1200	145
Rear	2200	210

Total power (max): 3,000W



### Optional accessories:

- Connecting rail (TR60): \$600

HK\$ 9,800

Installation drawing for 3 sets of domino hobs

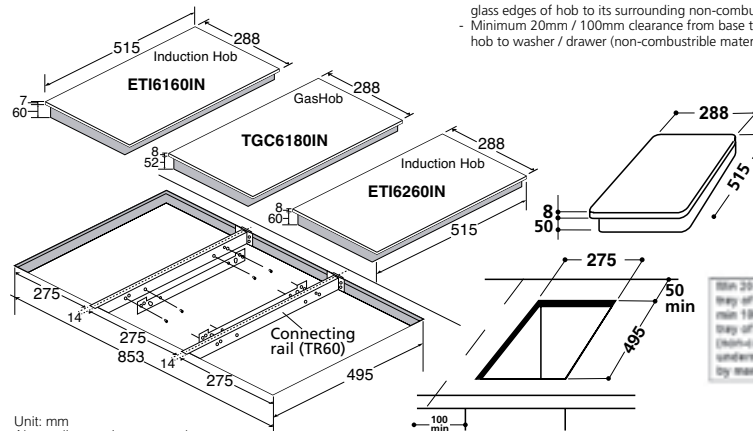

Side view

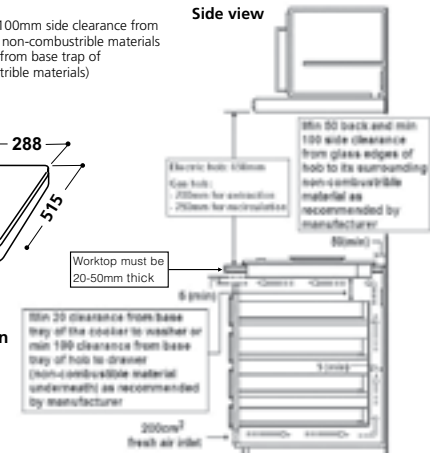

# ETI6160IN

Domino 1-head Induction Hob with Touch Control



## Bauknecht Hobs Range

### Design

- Full glass with LED display

### Control

- Touch control

### Cooking Feature

- Timer function

### Caring Features

- Safety switch off feature
- Residual heat indicator
- Acoustic minute minder
- Automatic pot detection
- Child lock
- Anti-spill control

### Green Feature

- SCHOTT CERAN® glass

### Optional Accessories

- Connecting rail

### Specifications

- Total power (max.): 3000W
- Spur unit: 20A
- Length of power cord: 1000mm
- Cooking zones diameter/outputs:

### Appliance Dimensions

- 58H x 288W x 515Dmm

### Cut Out Dimensions

- 275W x 495Dmm

### Country Of Origin

- Italy

Zone	Output (W)	Diameter (mm)
Middle	3000	210

Total power (max): 3,000W



### Optional accessories:

- Connecting rail (TR60): \$600

HK\$ 9,800

Installation drawing for 3 sets of domino hobs

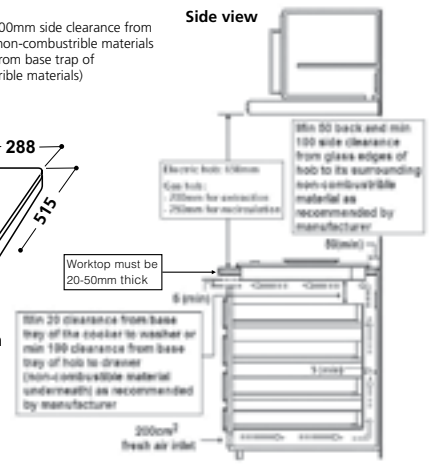
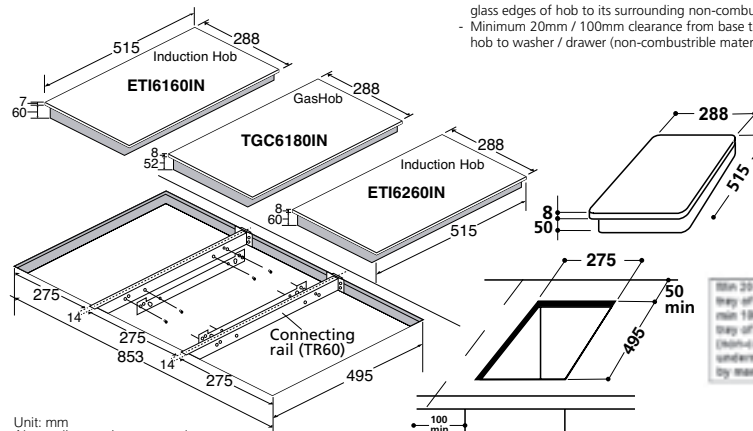

# TGZ6260/IN

Domino Gas Hob with 2 Burners



## Bauknecht Hobs Range

### Design

- Glass in black colour

### Control

- Silver painted knob control

### Caring Feature

- Electromagnetic safety valves

### Green Feature

- SCHOTT CERAN® glass

### Specifications

- Thermo-electric ignition fuse
- Length of power cord: 900mm
- Inlet gas pipe: 20mm
- Heat Input:

### Optional Accessories

- Connecting rail

### Appliance Dimensions

- 52H x 288W x 515Dmm

### Cut Out Dimensions

- 275W x 495Dmm

### Country Of Origin

- Italy

Zone	Town Gas (W)	LPG (W)
Front	1650	1650
Rear	3000	3000



### Optional accessories:

- Connecting rail (TR60): \$600

HK\$ 9,800

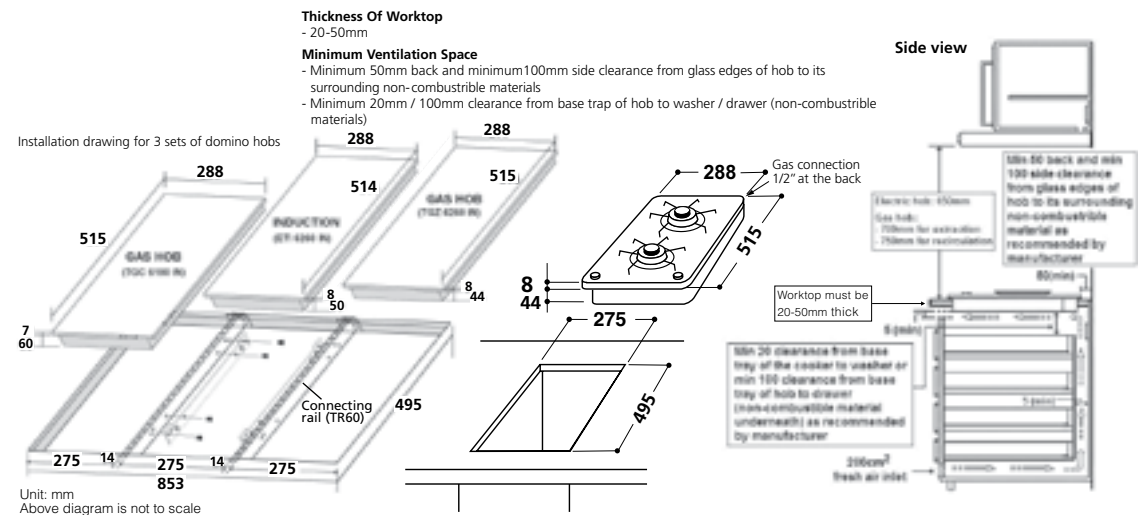

# TGC6180/IN

Domino Gas Hob with Single Burner



Bauknecht Hobs Range

### Design

- Glass in black colour

### Control

- Silver painted knob control

### Caring Features

- Safety valves
- Italian Sabaf® burner

### Green Feature

- SCHOTT CERAN® glass

### Specifications

- Heat Input:

### Optional Accessories

- Connecting rail

### Appliance Dimensions

- 67H x 288W x 515Dmm

### Cut Out Dimensions

- 275W x 495Dmm

### Country Of Origin

- Asia

Zone	Town Gas (W)	LPG (W)
Middle	5200	5000



### Thickness Of Worktop

- 20-50mm

### Minimum Ventilation Space

- Minimum 50mm back and minimum 100mm side clearance from glass edges of hob to its surrounding non-combustible materials
- Minimum 20mm / 100mm clearance from base trap of hob to washer / drawer (non-combustible materials)

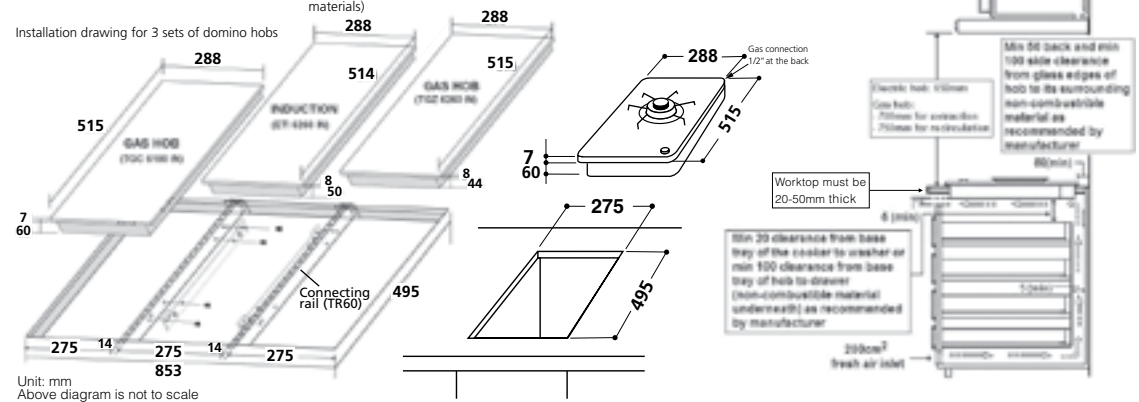

### Optional accessories:

- Connecting rail (TR60): \$600

HK\$ 9,800



“Elegance is not a dispensable luxury but a factor that decides between success and failure.”



# REFRIGERATORS & WINE CELLARS

GRANDNESS, INSIDE AND OUTSIDE.

If you're passionate about cooking, you know that the finest food starts with great ingredients. You choose them with care and preserve them in ideal conditions so they stay as fresh as just bought and keep all their quality, flavour and texture. That is why Bauknecht brings you the new refrigeration and wine collection which offer you excellent preservation conditions and flexibility whilst also meeting all your design requirements.



# Bauknecht's Allegro Collection

## Versatile, just like your need of space



### ALLEGRO COLLECTION. GUARANTEE ALL THE SPACE YOU NEED.

Not only do the shelves easily adjust to whatever height you want to make the best use of the space, but you can also completely reorganize your refrigerator to meet your specific requirements by customizing the large multipurpose bottom drawer compartment.

Bauknecht's new Allegro Collection comprises of incredible versatility that enables you to use this space in fridge, freezer or Dynamic 0° mode, the special function created especially for preserving fresh foods and specialty ingredients.



## SMART FEATURES TO PRESERVE WITH THE UTMOST CARE

The Dynamic 0° double drawer compartment guarantees all your fresh produce, meats, fish and dairy products are perfectly preserved in the optimum environment. It offers the best possible conditions for specialty cheeses and succulent filet mignon steaks, while keeping crispy salads crisper and leafy vegetables as fresh as the day they were bought.

Low temperatures in combination with correct humidity levels slow down the proliferation of bacteria and decay and prevent fresh foods losing moisture, keeping everything fresher for longer. Just select a temperature between -2 and +2 degrees for the drawers, and the humidity level in the compartment is automatically adjusted accordingly.

# Built to your preferred combination

## **MULTI-TEMPERATURE**



### MULTI-TEMPERATURE DRAWER

The Multi-Temperature Drawer can be used as additional fridge space, or switched to Dynamic 0° mode to give you more room for your freshest produce and specialty ingredients.

It also functions as a freezer for storing your frozen goods or freezing your favourite homemade dishes so they are always ready when needed.

## **ADJUSTABLE SHELVES**



### EASILY ADJUSTABLE SHELVES

Creating and managing space in your refrigerator has never been easier. The shelves can be conveniently split and individually adjusted to any height, transforming the interior into a well-organised, versatile space that's wonderfully practical and designed for all your needs.



## ICE CUBE MAKER



### AUTOMATIC ICE MAKER

The Allegro refrigerator is equipped with a fully automatic Ice Maker, with an option to connect directly to the water supply, and an integrated water filtering system that guarantees your ice cubes are always completely odourless and tasteless.



## DUAL-MOVEMENT HINGES



### DUAL-MOVEMENT HINGES

Patented dual-movement hinges combine technological innovation and design. These dual-movement hinges guarantee unlimited flexibility when designing your kitchen as it fits flush with cabinetry and countertops to ensure a sleek, luxurious finish. Each hinge has a self-balancing movement for guaranteed stability and long-lasting premium performance.



## LED



### LED LIGHTING

Creating an enhanced sense of space, the strategically-placed LED lights ensure you find what you're looking for with maximum illumination and minimum energy consumption.

# Bauknecht's Allegro Collection

## Optimal storage for the perfect glass



### A PEACEFUL DWELLING FOR YOUR PRECIOUS VINTAGES

For wine experts and enthusiasts, the Allegro wine cellar is designed for ideal storage of fine wines.

The preservation zone, equipped with humidity and temperature level controls, is a dedicated compartment for the ideal preservation of gourmet and vintage wines, whose key parameters can be modified at any time to best suit the stored bottles.

The pull-out shelves are made of natural wood, the stratified glass door blocks UV rays, while the anti-vibration system minimizes movement, creating the ultimate protecting environment for the most delicate bottles and preserving them to be enjoyed over time.





## PRESERVE AND AGED RED WINE

Allegro wine cellars offers so much more than a simple wine cooler. With precision temperature and humidity control, the compartment is suitable for preserving and aging fine red wines. It provides the ideal conditions for corks and allows your precious vintages to develop to their full potential, just as if they were stored in your own underground cellar.



### **UV PROTECTION**

#### 3 LAYERS OF PROTECTION.

Allegro wine cellars feature a triple-glazed door with bronzed glass to guarantee maximum protection from harmful UV rays and any sudden changes in ambient temperature. The three layers of protection give you peace of mind knowing that nothing will affect the quality and flavour of your wine.

### **ANTI-VIBRATION**

#### ANTI-VIBRATION SYSTEM

Effective compressor insulation guarantees full protection from vibration. Its anti-vibration system minimizes any movement, creating the safest environment for even the most delicate bottles so you can preserve them to be enjoyed at your leisure whatever the occasion.

# Optimal freshness for a healthier lifestyle



## FOOD STAYS PERFECTLY FRESH AND LASTS FOR LONGER

We understand you like to use fresh ingredients when cooking, and this makes it all the more important that fresh foods are stored properly. The patented Profresh Technology, together with Green Intelligence™ Technology, precisely monitors humidity and temperature – two factors crucial for ideal storage conditions. We care for your health, as do you.



# ProFresh.



## RETAINS IDEAL HUMIDITY AS PROVEN BY GERMAN TEST INSTITUTE

With the ProFresh™ technology, the compressor and fan operate separately. The compressor is switched on and off to adjust temperature within the refrigerator, while the fan reintroduces moisture that is condensed on the evaporator into the cavity. This way, food is stored at the ideal humidity of 70-85% and temperature variation is minimised. Food items stay fresh up to 4 times longer in your Bauknecht refrigerator than under conventional storage conditions, with valuable nutrients freshly preserved for your daily enjoyment. This way, ProFresh™ also saves you time, because your weekly food shopping stays really fresh.



# GREEN INTELLIGENCE™

## RECOVERS TEMPERATURE 5 TIMES FASTER

Your Bauknecht refrigerator is equipped with our innovative Dynamic Intelligence sensor technology, which automatically regulates the temperature of the compartments to compensate for any variation. If refrigerator temperature rises due to increased food load or door opening, the three Green Intelligence™ sensors will immediately detect the change and swiftly restore the temperature to optimal value. This way, refrigerator temperature recovers 5 times faster, while freezing in the freezer compartment is achieved 30% faster, thus reducing energy consumption by 30%.

# Optimal temperature and energy saver, all at once

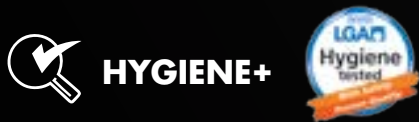

## ELIMINATING UP TO 99% OF BACTERIA

Hygiene+ filter offers exceptional anti-bacterial capabilities without the use of chemicals. It inhibits the spread of health-threatening bacteria and mould inside the refrigerator for a cleaner and healthier environment with less odours and cross-contamination, giving the best conditions for storing fresh food items. The filter can be replaced twice a year.



## DOUBLE ELECTRONIC PADDLES FILL CONTAINERS OF ANY SIZE

Two paddles – one for ice, one for water with a rotating nozzle – let you fill containers of any size and shape. The professional water filter can purify 1500L of water before it needs to be replaced. The flow rate of the water dispenser is 1.51L per minute, while on the ice maker it is 1.13L per minute.



## ICE CUBE MAKER WITH THE LARGEST 5.5L ICE STORAGE

Bauknecht provides you with not only chilled filtered water at the press of a button, but also ice cubes and crushed ice for your favourite drinks.

With the largest ice storage in the market, the extra large 5.5L ice cube maker is capable of making 1.3kg of ice per day. It can also be detached to use to serve chilled drinks at your table.

**0°C** **GOURMET FRESHBOX**



## GOURMET FRESHBOX KEEPS FOOD FRESH 3 TIMES LONGER

The Gourmet FreshBox is a freshness compartment for storing perishable foods like fish, meat and dairy products under the best conditions. At almost 0°C and low humidity, these foods can remain fresh up to 3 times longer.

**A++ ENERGY CLASS**



## SAVES 29% ENERGY COMPARED TO CLASS A+

Class A+ energy efficiency means 24% more savings than Class A. Bauknecht's A++ energy-efficient refrigerators reduce consumption by a further 29% compared to Class A+. So you can actively contribute to conserving the environment on a daily basis, while watching your energy bills go down.

*StarLight\**



## ATTRACTIVE AND ECO-FRIENDLY LED LIGHTING

The interior lighting system utilises LED lights, which not only uses less energy, but also radiates lesser heat than traditional light bulbs.

# Thoughtful design for the perfect bottle



The Bauknecht wine cellar has been designed to safely store a maximum number of bottles. The wine serving cabinets are fitted with patented ProGlide shelves, making it easier to access individual bottles. While keeping each bottle isolated, the design allows you to display your prized collection in one row. With Bauknecht's wine cellars, you will have the perfect bottle for every occasion, always.



## FLUSH-FITTING AND SPACE-SAVING, GUARANTEED

Bauknecht wine cellars have been designed to flush-fit into kitchen units. Thanks to its dimensions, it also adapts to kitchen design requirements. The front ventilated system at the base of the wine cellar allows it to be pushed to the very back – a true built-in solution.



**PROGLIDE**

## PATENTED SOLUTION FOR SAFEST SUPPORT

The patented ProGlide shelves are made with dual material, combining a rigid structure for holding the bottle and a flexible material which adapts to the shape of the bottle, which protects it from vibration. The shape of the ProGlide shelves are designed to optimise air circulation through the cabinet, and provides ergonomic individual bottle support just like being served by a wine steward.

Depending on the size of the bottles, it is possible to change the configuration by moving, removing or adding shelves with simple steps.

# Optimal temperature and energy saver, all at once

## XXL CAPACITY



### LARGE CAPACITY OF UP TO 167 BORDEAUX BOTTLES

The compact wine cellar holds up to 56 Bordeaux bottles, and the full height cellar is able to hold up to 167 Bordeaux bottles. This means that whatever the occasion, you will always have enough wine that are all kept in prime condition.

## THERMAL SYSTEM



### OPTIMAL STORAGE TEMPERATURE AT 5 - 22°C

The two enemies of wine are extreme temperatures and sudden changes in temperature. The walls of the wine cellars are made with a 5cm thick cellular insulant, and with the help of thermal control systems, storage temperature is kept between 5°C and 22°C to keep your favourite vintage at its best.

## HUMIDITY+



### OPTIMAL HUMIDITY TO ENSURE LABELS WON'T COME OFF

Exclusive humidity preservation and management systems keep humidity between 50% - 85% to prevent corks from drying out and losing their sealing abilities. And as every wine lover knows, it is essential to keep the labels of your prized collection intact. Additionally, the interior of the wine cellar is an integral body made with one piece, and with a crimped aluminum wall to maintain a relative humidity rate of between 60 - 75%.



 **CHARCOAL  
FILTER**



## NATURAL VENTILATION WITH FILTERED AIR

A constant supply of external filtered air is essential to prevent unpleasant odours and mould development. A charcoal filter ensures slow-flowing, filtered air and prevents undesirable odours which could spoil the taste of the wine. To ensure optimal performance, we recommend changing the filter every year.

 **UV  
PROTECTION**



## UV-RESISTANT DOORS PROTECT IT FROM THE DANGERS OF LIGHT

Light, particularly its UV component, causes wine to quickly deteriorate by irreversible oxidations of tannins. Bauknecht's wine cellar comes with UV-proof glass doors so your wines will be protected from light.

 **ANTI-VIBRATION**



## 4 MAJOR PROTECTION TO PREVENT VIBRATIONS

Vibrations will ruin your prized collection. Our thoughtful features provide several levels of protection, like maintaining perfect stability using adjustable rubber feet, ProGlide shelves equipped with shock absorbers, a compressor fitted with 4 silent blocks and a compressor bracket that is independent of the body.



# KGIN3210

90cm Fully Integrated Refrigerator

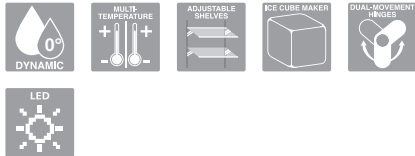

## Design

- Built-in type
- Soft closing door system

## Control

- Electronic control
- Digital temperature display
- Control panel lock
- Independent temperature control
- Black out memory

## Caring Features

- Multi temperature drawer
- Dual movement hinge
- Even airflow system
- Fast cooling
- Fast Freezing
- High temp alarm
- Bottle cooler
- Triple zone
- Adjustable balconies

## Green Features

- Europe energy class A+
- LED lighting
- No frost system
- Vacation mode
- Door open alarm

## Interior Space Management

- Fridge
  - > 4 Glass shelves
  - > 2 Drawers
  - > 3 Height adjustable balconies
  - > Cheese and meat fresh zone
  - > 5 Door racks
- Freezer
  - > Ice maker

## Specifications

- Total capacity: 429L
- Fridge capacity: 220L
- Drawer capacity: 96L
- Freezer capacity: 113L
- Noise level: 44dB(A)
- Annual energy consumption: 474kWh
- Freezing capacity: 15kg in 24hrs
- Rising time: 15hrs
- Socket / Fuse spur unit: 13A

## Appliance Dimensions

- 2050H x 887W x 575Dmm

## Cut out Dimensions

- 2064H x 900W x 605Dmm

## Country Of Origin

- Europe

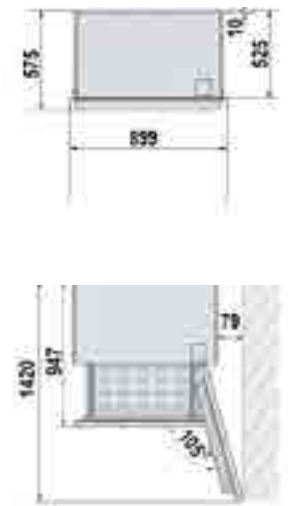
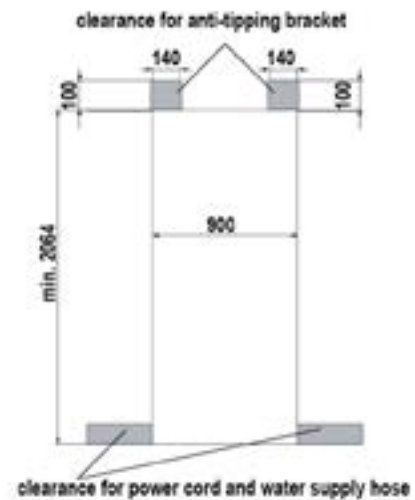
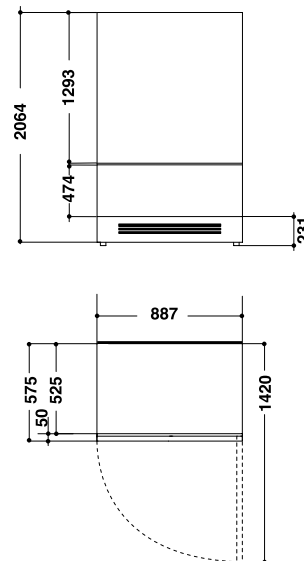

HK\$ 75,800

# SF3210

60cm Fully Integrated Wine Cellar

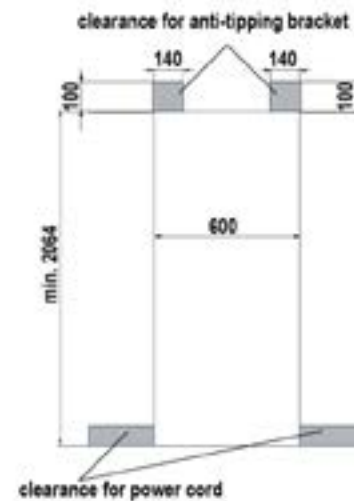
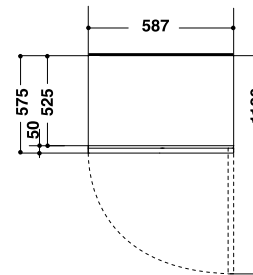
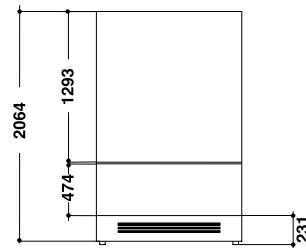

## Bauknecht Wine Cellar Range

### Design

- Built-in type
- Soft closing door system

### Features

- Electronic control
- Digital display
- Dual Movement hinges
- Multi-temperature drawers
- Soft closing system
- Independent temperature control
- Even airflow system
- Anti-vibration system
- Preserve & Age red wine cell

### Green Features

- Europe energy class A+
- LED lighting system

### Specifications

- Capacity:
- Multi-temperature drawer: 55L
  - Top compartment: 47L
- Bottle Capacity:
- Top compartment: 30
- Temperature range:
- Top compartment: 4 to 12°C
  - Multi-temperature drawer: -15 to + 2°C
- Number of wood sliding shelves: 9
- Socket / Fuse spur unit: 13A

### Appliance Dimensions

- 2050H x 587W x 575Dmm

### Cut Out Dimensions

- 2064H x 600W x 605Dmm

### Country of Origin

- Italy

HK\$ 69,800

# KSN570A+GW

Side-by-Side Refrigerator with White Glass Front



## Bauknecht Refrigerator Range

### Design

- Side-by-Side freestanding type
- White glass front with integrated handle

### Control

- Electronic button control
- Digital temperature display
- Independent control of fridge and freezer
- Control panel lock

### Caring Features

- Fridge
  - > Hygienic fresh keeping drawers
  - > Anti-bacterial filter
  - > Multiflow system
- Freezer
  - > Extendable water dispenser with 2 electric paddles
  - > Turbo freeze

### Green Features

- Europe energy class A+
- Green Intelligence Technology
- No-frost system
- Vacation mode

### Interior Space Management

- Fridge
  - > 4 Shelves made of safety glass
  - > Stainless steel bottle rack
  - > Snack compartment
  - > Cheese and meat fresh zone
  - > 5 Door racks
- Freezer
  - > In-Door-Ice system
  - > Ice maker with ice cube container
  - > Removable 8L ice cube holder
  - > 3 Shelves
  - > 2 Transparent freezing drawers
  - > 2 Door racks

### Specifications

- Total net capacity: 505L
- Fridge net capacity: 325L
- Freezer (4 stars) net capacity: 180L
- Noise level: 45dB(A)
- Annual energy consumption: 438kWh
- Freezing capacity: 12kg in 24hrs
- Rising time: 5hrs
- Socket / Fuse spur unit: 13A
- Length of power cord: 2000mm
- Inlet water pipe: 1250mm

### Appliance Dimensions

- 1780H x 905W x 700Dmm

### Country of Origin

- Italy



GREEN INTELLIGENCE

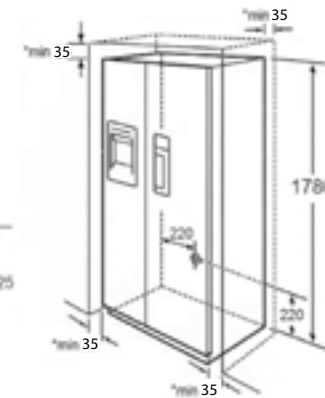
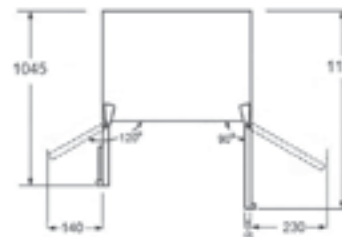
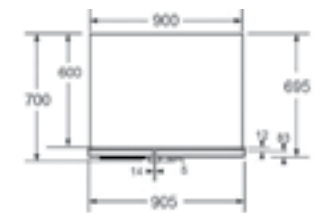

\* Recommended ventilation space

Unit: mm  
Above diagram is not to scale

HK\$ 35,800

# KSN505A++IL

Side-by-Side Refrigerator



## Bauknecht Refrigerator Range

### Design

- Side-by-Side freestanding type
- Inox front with handle

### Control

- Electronic button control
- Digital temperature display
- Independent control of fridge and freezer
- Control panel lock

### Caring Features

- Fridge
  - > Hygienic fresh keeping drawers
  - > Anti-bacterial filter
  - > Multiflow system
- Freezer
  - > Fast freeze

### Green Features

- Europe energy class A++
- Green Intelligence Technology
- No-frost system
- Vacation mode

### Interior Space Management

- Fridge
  - > 4 Shelves made of safety glass
  - > Snack compartment
  - > Cheese and meat fresh zone
  - > 5 Door racks
- Freezer
  - > 3 Shelves
  - > 2 Transparent freezing drawers
  - > 5 Door racks

### Specifications

- Total net capacity: 542L
- Fridge net capacity: 335L
- Freezer (4 stars) net capacity: 207L
- Noise level: 45dB(A)
- Annual energy consumption: 364kWh
- Freezing capacity: 12kg in 24hrs
- Rising time: 5hrs
- Socket / Fuse spur unit: 13A
- Length of power cord: 2000mm

### Appliance Dimensions

- 1780H x 902W x 740Dmm (700Dmm without handle)

### Country Of Origin

- Europe



GREEN INTELLIGENCE

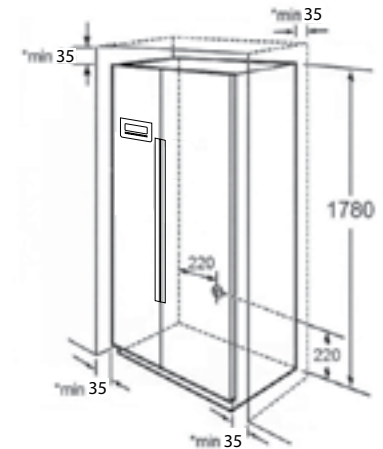
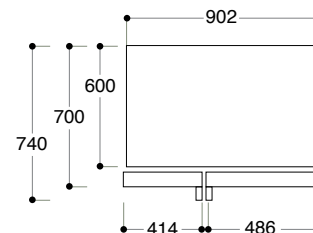
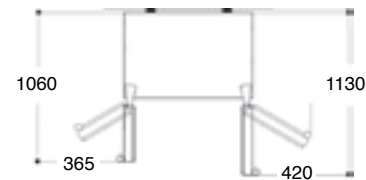
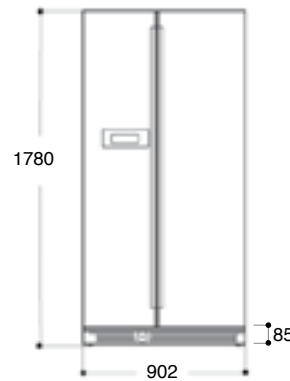

\* Recommended ventilation space

HK\$ 27,800

# KGIN3183A++

Fully Integrated Refrigerator



## Bauknecht Refrigerator Range

### Design

- Fully integrated refrigerator
- Right-hinged door (inter-changeable)

### Control

- Electronic button control
- Digital temperature display
- Independent control of fridge and freezer
- Control panel lock

### Caring Features

- Door open alarm
- Active ventilation system for uniform temperature distribution
- Fridge
  - > Antibacterial filter
- Freezer
  - > Temperature alarm
  - > Super freeze

### Green Features

- Green intelligence technology
- No-frost freezer
- StarLight LED lighting
- Eco night function
- HK energy label Grade 1\*

### Interior Space Management

- Fridge
  - > 5 Shelves made of safety glass
  - > 4 Door racks
  - > 1 Vegetable tray

### Accessories Supplied

- Ice cube tray

### Specifications

- Total net capacity: 258L
- Fridge net capacity: 197L

- Freezer (4 stars) net capacity: 61L
- Noise level: 38dB(A)
- Annual energy consumption: 237kWh
- Cool performance ratings: 4 stars
- Freezing capacity: 9kg in 24hrs
- Rising time: 16hrs
- Socket / Fuse spur unit: 13A
- Length of power cord: 2000mm

### Appliance Dimensions

- 1770H x 540W x 545Dmm

### Cut Out Dimensions

- 1776H x 560W x 555Dmm

### Country Of Origin

- Italy

\*Based on EMSD code of practice in Year 2010



GREEN INTELLIGENCE

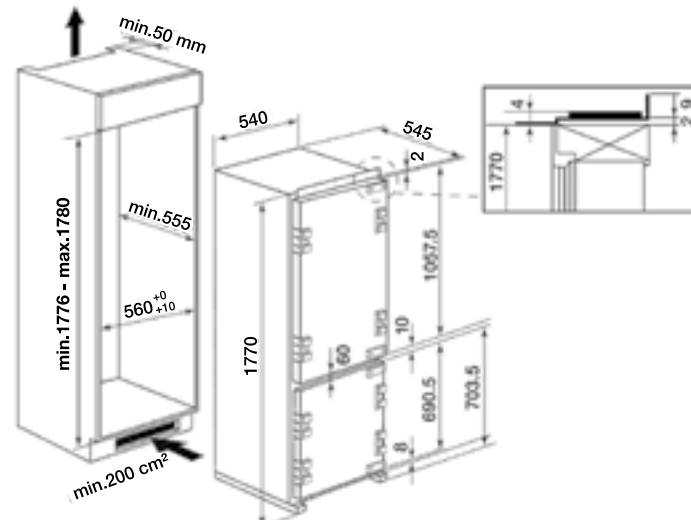

Socket on the side of appliance.  
Unit: mm  
Above diagram is not to scale

HK\$ 28,800

# KGIN31811/A+

Fully Integrated Refrigerator



## Bauknecht Refrigerator Range

### Design

- Fully integrated type
- Right-hinged door (inter-changeable)

### Control

- Electronic button control
- Digital temperature display
- Independent control of fridge and freezer
- Control panel lock
- Door open indicator of freezer

### Caring Features

- Door open alarm
- Active ventilation system for uniform temperature distribution
- Fridge
  - > Antibacterial filter
  - > Multiflow system
- Freezer
  - > Temperature alarm
  - > Super freeze

### Green Features

- HK energy label Grade 1\*
- No-frost freezer
- Vacation mode
- StarLight LED lighting

### Interior Space Management

- Fridge
  - > 5 Shelves made of safety glass
  - > 4 Door racks
  - > 1 Vegetable tray

### Accessories Supplied

- Egg tray
- Ice cube tray

### Specifications

- Total net capacity: 262L
- Fridge net capacity: 199L
- Freezer (4 stars) net capacity: 63L
- Noise level: 38dB(A)

- Annual energy consumption: 296kWh
- Freezing capacity: 9kg in 24hrs
- Rising time: 16hrs
- Socket / Fuse spur unit: 13A
- Length of power cord: 2250mm

### Appliance Dimensions

- 1770H x 540W x 545Dmm

### Cut Out Dimensions

- 1776H x 560W x 555Dmm

### Country Of Origin

- Italy

\*Based on EMSD code of practice in Year 2010

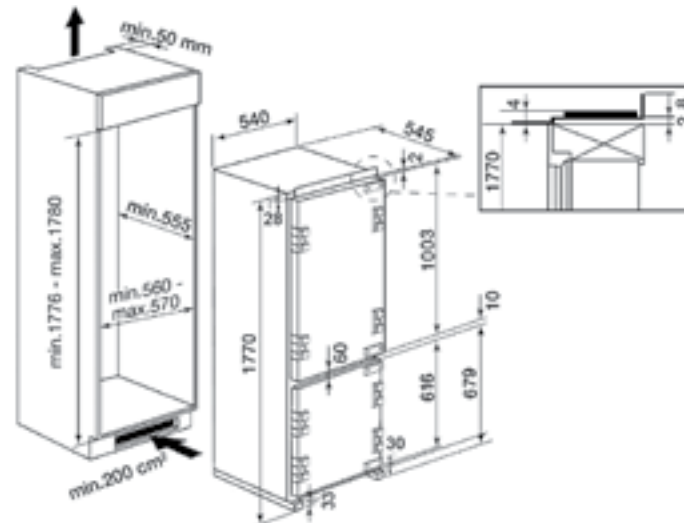

Socket on the side of appliance.  
Unit: mm  
Above diagram is not to scale

HK\$ 25,800

# KGIE3205/A++

Fully Integrated Refrigerator

## Bauknecht Refrigerator Range



### Design

- Fully integrated type
- Right-hinged door (inter-changeable)

### Control

- Electronic button control
- Digital temperature display
- Independent control of fridge and freezer
- Control panel lock

### Caring Features

- Door open alarm
- Active ventilation system for uniform temperature distribution
- Fridge
  - > Antibacterial filter
  - > Multiflow system
- Freezer
  - > Temperature alarm
  - > Super cool and Super freeze

### Green Features

- Europe energy class A++
- HK energy label Grade 1\*
- Vacation mode
- StarLight LED lighting

### Interior Space Management

- Fridge
  - > 5 Shelves made of safety glass
  - > 4 Door racks
  - > 2 Vegetable trays
- Freezer
  - > 3 Transparent freezer drawers

### Specifications

- Total net capacity: 264L
- Fridge net capacity: 200L
- Freezer (4 stars) net capacity: 64L
- Noise level: 37dB(A)

- Annual energy consumption: 204kWh
- Freezing capacity: 9kg in 24hrs
- Rising time: 19hrs
- Socket / Fuse spur unit: 13A

### Appliance Dimensions

- 1770H x 540W x 545Dmm

### Cut Out Dimensions

- 1776H x 560W x 555Dmm

### Country Of Origin

- Italy

\*Based on EMSD code of practice in Year 2010

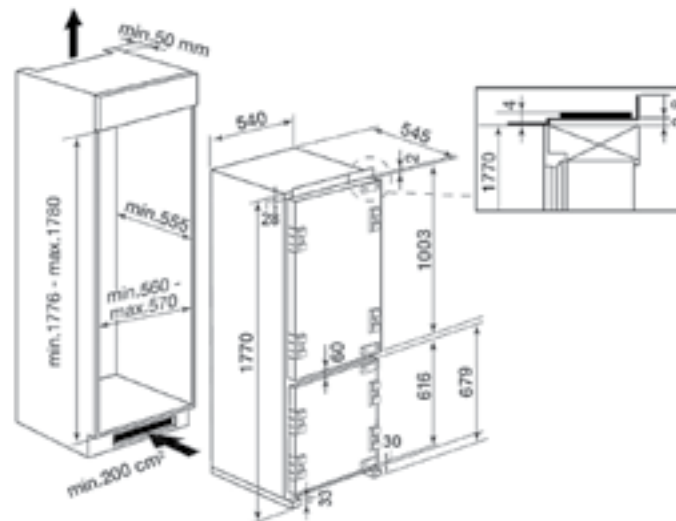

Socket on the side of appliance.  
Unit: mm  
Above diagram is not to scale

HK\$ 18,800



# S2560

Full Height Wine Cellar



## Bauknecht Wine Cellar Range

### Design

- Full glass door with black trim
- Double temperature display (low temp + high temp)
- Electronic display
- Allow for flush-fitted or freestanding

### Features

- Bottle capacity: 118 (167 bottles max capacity)
- 14 ProGlide sliding shelves
- Humidity Control
- Front vented ventilation
- Active charcoal filter
- Reversible full glass door
- Interior LED lighting with UV protection
- Thermal Insulation
- Double-layered door glass
- Double sensors

### Control

- Electronic Touch Control

### Caring Features

- Anti-vibration compressor
- Open Door Alarm
- Charcoal Filter Alarm
- Temperature Alarm
- Lighting selection key
- Humidity Alarm
- Lock
- Adjustable feet

### Specifications

- Temperature range: 5°C - 22°C
- Ambient room temperature for usage: 12°C - 35°C
- Humidity range: 50% - 85%
- Number of shelves: 14
- Consumption per 24hr: 0.45kWh
- Socket / Fuse spur unit: 13A
- Length of power cord: 1300mm

### Optional Accessories

- Presentation shelves

### Appliance Dimensions

- 1792H x 595W x 566Dmm

### Cut Out Dimensions

- 1800H x 600W x 571Dmm

### Country Of Origin

- France

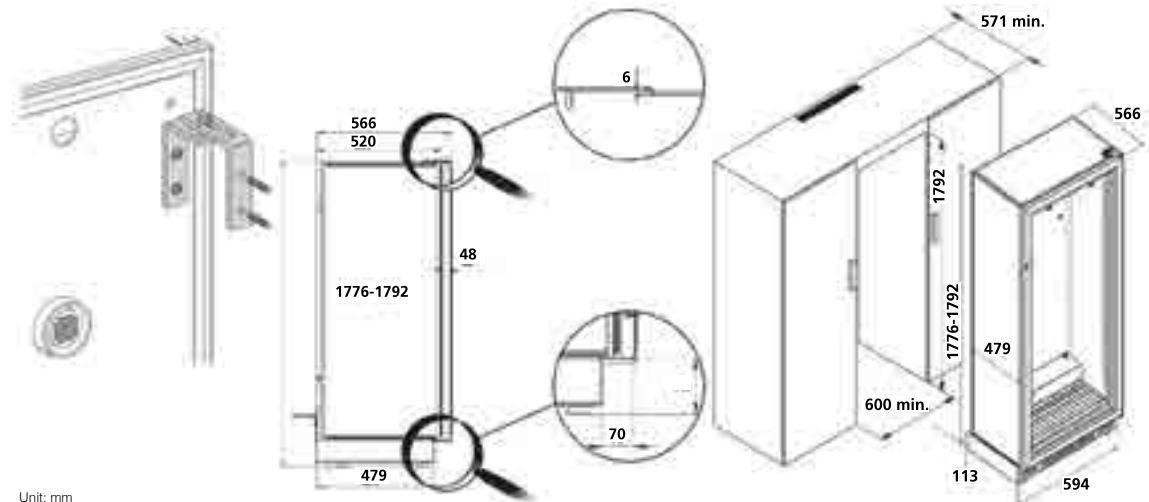
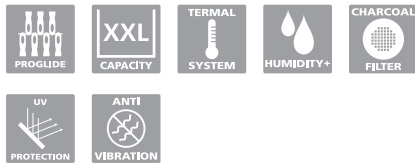

Unit: mm  
Above diagram is not to scale

HK\$ 49,800

# S560

Built-under Wine Cellar



## Bauknecht Wine Cellar Range

### Design

- Full glass door with black trim
- Double temperature display (low temp + high temp)

### Features

- Bottle capacity: 38 (56 bottles max capacity)
- 4 ProGlide sliding shelves
- Front vented ventilation
- Active charcoal filter
- Reversible full glass door
- Interior LED lighting with UV protection
- Thermal Insulation
- Double-layered door glass
- Double sensors

### Control

- Electronic Touch Control

### Caring Features

- Anti-vibration compressor
- Open Door Alarm
- Charcoal Filter Alarm
- Temperature Alarm
- Lighting selection key
- Lock

### Specifications

- Temperature range: 5°C - 22°C
- Ambient room temperature for usage: 12°C - 35°C
- Humidity range: 50% - 85%
- Number of shelves: 4
- Consumption per 24hr: 1.03kWh
- Socket / Fuse spur unit: 13A
- Length of power cord: 1300mm

### Appliance Dimensions

- 820H x 597W x 560Dmm

### Cut Out Dimensions

- 837-853H x 600W x 570Dmm

### Country Of Origin

- France

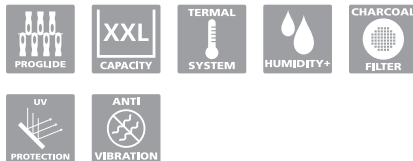

Side view

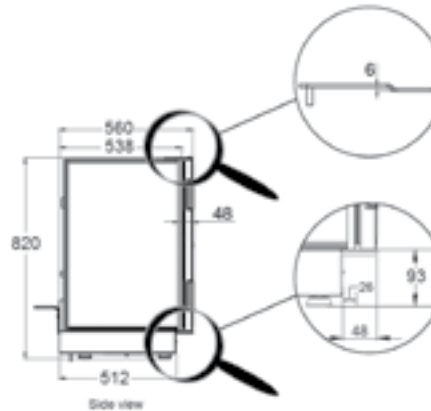

Side view

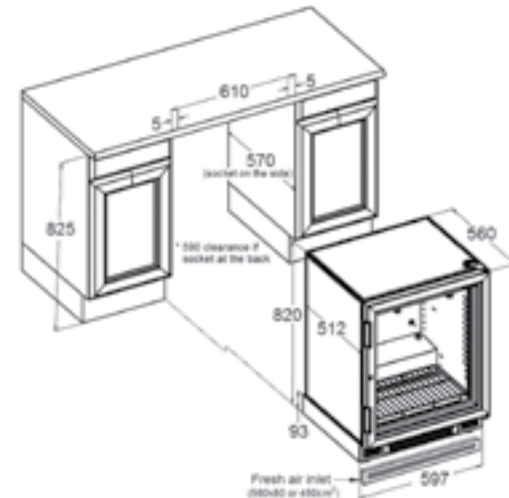

HK\$ 32,800

Unit: mm  
Above diagram is not to scale





“Time is too slow for those who wait, too short for those who rejoice.”



# DISHWASHERS

CLEANS AND DRIES YOUR DISHES PERFECTLY IN JUST 1 HOUR.

Bauknecht gives you more “me-time” thanks to its innovative dish care technology. The award-winning PowerDry dishwasher by Bauknecht not only cleans and dries your dishes perfectly in just 1 hour, but it also takes care of your plastic items and glasses. The PowerDry dishwasher was awarded the 2014 KitchenInnovation of the year award and also won Bauknecht the title of consumers’ favourite brand 2014.



# The innovation that has revolutionized dishwashing



## CLEANING AND DRYING IN JUST ONE HOUR\*

PowerDry is a unique patented technology that ensures excellent drying results, thanks to a closed system that removes humidity from the cavity through a condensation process.

The unique PowerDry ventilation system with double air circulation means that, after rinsing, moisture inside the dishwasher is deliberately removed and condensed. Thus, when opening the dishwasher right after the cleaning process, there will be no presence of steam. Dishes can be immediately removed from the dishwasher without the risk of burning.

\*With the "1hour wash & dry" program and the PowerClean+ feature not in use. (Status:03/2014).



## THE 1 HOUR WASH & DRY PROGRAM

The 1 hour wash & dry is a special program developed to last only 1 hour, for perfectly washed daily load. The program automatically activates the PowerDry option to deliver outstanding drying results.





After last rinsing phase, humidity inside the cavity is sucked by the upper inlet and directed to the condenser.



At the same time, the fan is activated and blows cool air around the condenser, reducing the temperature of air passing through.



As a result, condensed air comes back as water drops into the cavity through the lateral inlet.



## ULTIMATE SPOTLESS DRYING EVEN ON PLASTIC ITEMS

PowerDry has been developed to provide outstanding drying results on plastic items. Get maximum shine without the use of a towel, no risk of water-stains nor dripping on the kitchen floor. Your plastics & dishes can be placed straight into a cupboard or on the table!



# Intelligent programmes, enjoyable dishwashing

## POWER CLEAN PLUS



### NO PREWASH WITH 28 POWERFUL JET SPRAYS

PowerClean+ is a patented technology that provides best cleaning results even on burnt-on soil pots or large items with no need to prescrub. The sensor will automatically detect the level of soil and will adjust the PowerClean+ water jet pressure accordingly.

## Flexi space



### MORE SPACE, MORE FLEXIBILITY

The rack has been specifically developed to allow special vertical loading of pots in the PowerClean+ area, creating a free space in the lower for up to 10 additional dishes.

\*Compared to a Bauknecht dishwasher without PowerClean+ function, washing 2 pans.

## HYGIENE+



### MICROBAN-TREATED FILTER REMOVES 99% BACTERIA

Bauknecht's dishwashers are equipped with the first hygiene protection system certified by the German LGA test institute. Water is raised to 72°C at the end of the washing cycle to remove 99.999% of bacteria. The special Microban antibacterial protection, integrated in the Hygiene+ filter, ensures that no bacteria is lodged in the system.



## PATENTED TECHNOLOGY ACHIEVES 50% ENERGY SAVINGS

The Green Intelligence technology is the Bauknecht solution for smart optimization of resources. Advanced sensors recognize the type of load and the level of soil and automatically adjusts the amount of water, temperature and time, allowing up to 50%\* saving.

\*Comparison between min. and max. water and electricity consumption, and between longest and shortest duration in the Bauknecht Sensor programme.



## A+++ ENERGY EFFICIENCY



## TOP-IN-CLASS ENERGY EFFICIENCY

PowerDry also minimizes the energy required to dry in combination with ultra efficient variable speed motors. When PowerDry is activated, the cycle duration is reduced up to 35 minutes, without increasing energy consumption. The system delivers a top efficiency energy class (A+++).



## GLASS PROGRAMME



## GENTLE WASHING AT 40°C TO ENSURE NO BREAKAGE

Fragile glasses and porcelain can now be washed in the machine without worries. At 40°C the Glass programme cleans your crockery gently and thoroughly – water consumption is much lower than when you wash by hand.

# GSXPX384A3

Fully-integrated Dishwasher



## Bauknecht Dishwashers Range

### Design

- Fully integrated type

### Control

- Electronic touch control
- Start time pre-set: 0.5-24 hours

### Caring Features

- PowerClean Plus Technology
- PowerDry
- Overflow protector
- Hygiene+ filter
- Operation Light on floor
- End of cycle indicator

### Green Features

- Green Intelligence Technology
- Energy / Cleaning / Drying performance: A+++AA
- Multizone programme

### Cleaning Programs

- Sensor power clean plus program 40°C - 70°C
- Glass program 40°C
- Express program 45°C
- 1 hour wash & dry 55°C
- Normal program 60°C
- Intensive 65°C
- Night program 50°C
- Steam 70°C

### Specifications

- 13 Place settings
- Consumption rates
- Water: 7.7L
- Electricity: 0.64kWh
- Time: 185 minutes

- Minimum water consumption: 7.5L
- Sound level: 44dB(A)
- Socket / Fuse spur unit: 13A

### Appliance Dimensions

- 820H x 597W x 555Dmm

### Cut Out Dimensions

- 820-900H x 600W x 580Dmm

### Country Of Origin

- Europe



POWER CLEAN PLUS

PowerDry

GREEN INTELLIGENCE

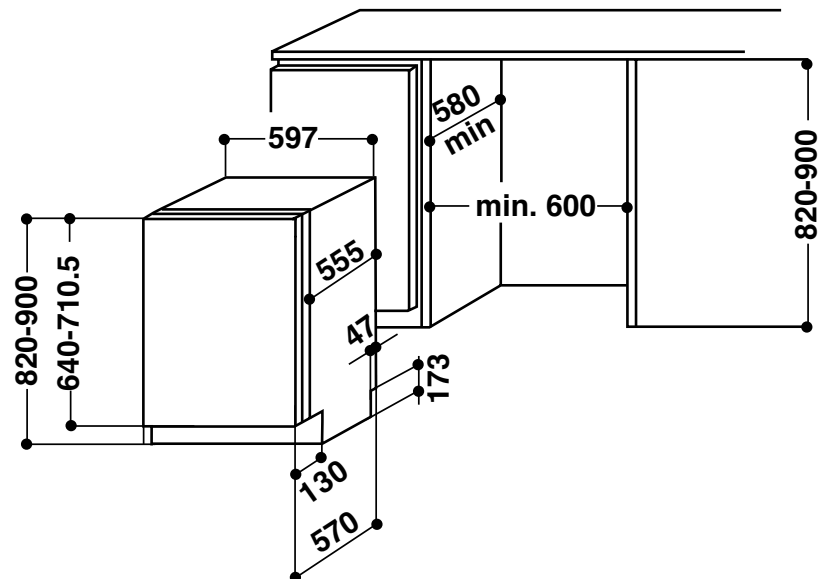

HK\$ 20,800

# GSIPX384A3P

Semi-integrated Dishwasher



## Bauknecht Dishwashers Range

### Design

- Semi-integrated type

### Control

- Electronic touch control
- Start time pre-set: 0.5-24 hours

### Caring Features

- PowerClean Plus Technology
- PowerDry
- Overflow protector
- Hygiene+ filter
- Operation Light on floor
- End of cycle indicator

### Green Features

- Green Intelligence Technology
- Energy / Cleaning / Drying performance: A+++AA
- Multizone programme

### Cleaning Programs

- Sensor power clean plus program 40°C - 70°C
- Glass program 40°C
- Express program 45°C
- Eco program 50°C
- 1 hour wash & dry 55°C
- Normal program 60°C
- Intensive 65°C
- Night program 50°C
- Steam 70°C

### Specifications

- 13 Place settings
- Consumption rates
- Water: 7.7L
- Electricity: 0.64kWh

- Time: 185 minutes
- Minimum water consumption: 7.5L
- Sound level: 44dB(A)
- Socket / Fuse spur unit: 13A

### Appliance Dimensions

- 820H x 597W x 555Dmm

### Cut Out Dimensions

- 820-900H x 600W x 580Dmm

### Country of Origin

- Europe



POWER CLEAN PLUS

PowerDry

GREEN INTELLIGENCE

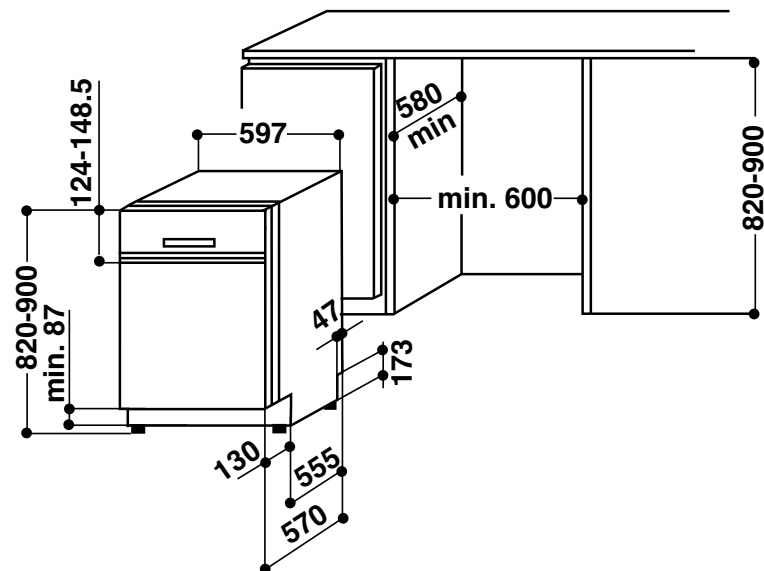

HK\$ 17,800

“Destiny is no matter  
of chance. It is a  
matter of choice.”







# WASHER DRYER

ALL-IN-ONE LAUNDRY EXPERTS WITH A VARIETY OF CHOICES.

Bauknecht washer dryers offer the perfect solution for your evolving washing & drying needs. It is loaded with up to 21 programs to cater to your specific requirements. It occupies minimum space with ultra slim depth but can perfectly wash up to 7kg of load and dry up to 5kg, offering optimum care for loads of varied colours, materials and texture.

# Unbeatably efficient washing and drying



## THE ENVIRONMENTALLY-CONSCIOUS LAUNDRY EXPERT

The Bauknecht washer has been awarded with the Energy and Water Efficient Grade 1 Class. Compared with Grade 5, Grade 1 is able to save energy and water respectively by up to 40%. This helps you to save money, while protecting the environment.

Its top in the class performance is further reinforced by A class energy efficiency, A class washing performance and A class spinning performance awarded by IEC. Its large capacity also reduces the frequency of washes, which saves energy, water and time.



## A FLEXIBLE WASHER DRYER THAT MEETS ALL YOUR NEED

Washing that works around your schedule, not the other way around FlexiTime reduces the duration of the cycle. You can easily select the wash time you desire from the large LED display panel according to your need. Bauknecht has taken a major step towards even greater convenience and flexibility when doing the laundry.





## DRYING SELECTIONS

### SUFFICIENT CHOICES TO CHOOSE FROM

When it comes to drying, there's also a range of drying programmes for your selection. Select the degree of dryness that you required based on different materials and humidity to achieve the best drying performance. Extra dry for bath towels & bathrobes; cupboard dry for items that will be put away without ironing; and Iron dry that leaves the laundry suitable for ironing. The washer dryer will automatically calculate the time needed for drying according to the load and drying type selected.

# Thoughtful programmes for laundry excellence

## STAIN WASH



### PERFECT CLEANING EVERYTIME

Stain wash is a specialized program for stubborn stains. Thanks to the unique distribution of detergent in a uniform manner and maximized cleaning action, stubborn stains can be eliminated at the same time without sacrificing the length of the program.

## INTENSIVE



### TOUGH CLEANING WITH A GENTLE TOUCH

In the intensive programme, the maximum temperature is changed to 90°C and the washing stage is extended to increase the effectiveness of the enzymes in the detergents. This is ideal for delicate but dirty items.

## WOOL SWING



### TENDER CARE FOR DELICATE CLOTHING

Wool wash with cradle swinging actions, as well as a delicately selected water temperature, spinning speed and washing time, all provide tender loving care for your delicate wool and silk wear.

## **RAPID WASH**



### **RAPID CLEANING FOR SMALLER, LIGHTER LOADS**

Rapid Wash reduces the duration of the washing cycle. This makes it a suitable feature for small amounts of laundry with only light dirt.

## **HAND WASH**



### **HAND WASH**

Hand Wash is a gentle and specialized programme. This programme allows a complete washing cycle for garments specified as "Hand Wash only" on the fabric care label as it runs under 30°C of temperature and at a slow spin.

## **EASY IRONING**



### **IRONING, NOW MADE MUCH EASIER**

Easy iron produces items which are less creased and easier to iron. Selected model features a gentler rinsing action and drying speed. At the end of the washing cycle, cold water will be introduced to lower the temperature, which spares you from difficult ironing.

## **DRUM CLEANING**



### **TAKES CARE OF ITSELF SO YOU WON'T NEED TO**

A self-cleaning programme intelligently cleans the interior of selected machine, which helps to avoid smells and deposits that build up within the machine over time.

# BKWD7140

Built-in Washer Dryer



## Design

- Fully-integrated type

## Control

- LED display
- Electronic button control
- Start delay (24 hrs)

## Caring Features

- Door security
- Anti-overflow
- Foam control
- Electronic spin speed management
- Electronic balance control

## Green Features

- HK energy label: Grade 1<sup>^</sup>
- HK water efficiency: Grade 1

## Washing Programmes

- Number of programmes: 15+
  - > Cotton / Wool
  - > Handwash
  - > Delicates
  - > Stain wash
  - > Anti-bacteria
  - > Shirts
  - > Eco
  - > Iron / Cupboard / Extra dry

## Specifications

- Washing capacity: 7kg
- Drying capacity: 5kg
- Consumption (washing only):
  - > Electricity: 1.19kWh

- Spin speed: 1400rpm
- Socket / Fuse spur unit: 13A
- Length of power cord: 1450mm
- Length of inlet pipes: 1430mm
- Length of outlet pipes: 1130mm

## Appliance Dimensions

- 820H x 596W x 532D\*(545#D)mm

## Cut Out Dimensions

- 825H x 600W x 545Dmm

## Country of Origin

- Italy

\* Depth from front panel to hose at the back (exclude door and button)

# Depth from front door to hose at the back (including door and button but not cabinet door)

<sup>^</sup> Based on EMSD code of practice in Year 2010

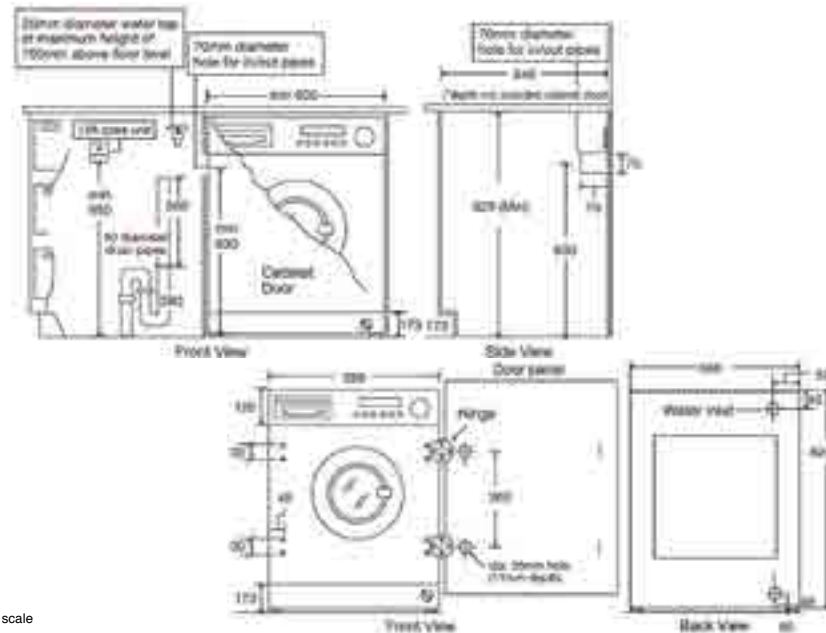

Unit:mm  
Above diagram is not to scale

HK\$ 17,800



# BKWD1200

Built-in Washer Dryer



HK\$ 12,800

## Bauknecht Washer Dryer Range

### Design

- Fully-integrated type

### Control

- LED display
- Electronic control system
- Start time pre-set

### Caring Features

- Remaining time indication
- Foam control
- Imbalance correction system
- Eco-ball
- Automatic adjustable water level

### Green Features

- HK energy label Grade 1\*
- Electronic wash optimisation

### Washing Programmes

- Number of programmes: 15
  - > Cotton
  - > Easy care / Synthetics
  - > Delicates

- > Wool

- > Easy iron

- > Pre-wash

- > Rinse hold

- > Intensive rinse

### Specifications

- Washing capacity: 6kg

- Drying capacity: 4kg

- Consumption:

- > Water: 59L

- > Electricity: 1.02kWh

- Average annual energy

- consumption: 204kWh

- Spin speed: 1200rpm

- Socket / Fuse spur unit: 13A

- Drain pipe: 1800mm

- Inlet water pipe: 1800mm

- Length of power cord: 2000mm

### Appliance Dimensions

- 818H x 596W x 546Dmm

### Country Of Origin

- Italy

\*Based on EMSD code of practice in Year 2010

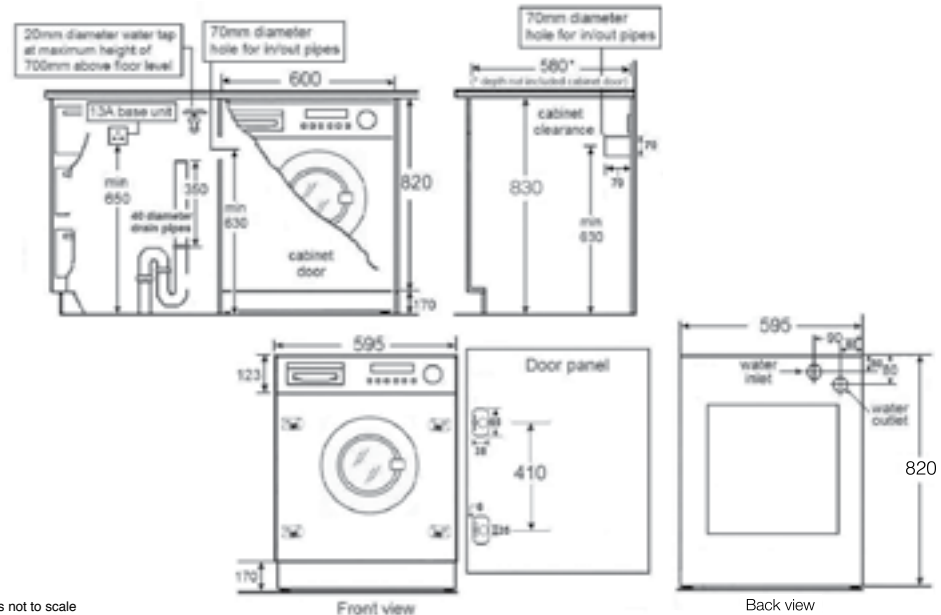







Scan the above QR code to  
download our full catalogue.

## Showroom

Bauknecht Place 1919  
G/F, Zoroastrian Building  
101 Leighton Road, Causeway Bay  
[www.bauknecht.com.hk](http://www.bauknecht.com.hk)

Austria • Belgium • Czech Republic • Denmark • Germany • Hong Kong • Hungary •  
Ireland • Netherlands • Russia • Slovakia • Switzerland • United Kingdom

BK 0415 (CB08) Bauknecht is a registered trademark. All rights reserved.



